

VHF-Transceivers 6200 Series

from Software Version
SCI1050S305 Version 4.06
SCI1051S305 Version 2.06

Installation and Operation

Manual DV14307.03

Issue 06 February 2021

Article-No. 0638.404-071

Approved Production and Maintenance OrganizationCertificates see: <http://www.becker-avionics.com/certification/> →Certificates

Contact data for:

**Europe, Asia,
Oceania and
Africa** **Becker Avionics GmbH**
Baden-Airpark B108
77836 Rheinmünster (Germany)
Tel.: + 49 7229 / 305-0
Fax: + 49 7229 / 305-217
Internet: www.becker-avionics.com
Email: info@becker-avionics.com

Customer Service:Email: support@becker-avionics.com

Contact data for:

**America,
Australia, Japan** **Becker Avionics Inc.**
Email: info@beckerusa.com

**WARNING - USER RESPONSIBILITY**

FAILURE OR IMPROPER SELECTION OR IMPROPER USE OF THE PRODUCTS DESCRIBED HEREIN OR RELATED ITEMS CAN CAUSE DEATH, PERSONAL INJURY AND PROPERTY DAMAGE.

This document and other information from Becker Avionics GmbH provide product or system options for further investigation by users having technical knowledge.

The user is responsible for making the final selection of the system and components. The user has to assure that all performance, endurance, maintenance, safety requirements of the application are met and warnings be obeyed.

For this the user has to include all aspects of the application to be compliant with the applicable industry standards and the requirements of the responsible aviation authority. The product documentations from Becker Avionics GmbH have to be obeyed.

To the extent that Becker Avionics GmbH provide component or system options based upon data or specifications provided by the user, the user is responsible for determining that such data and specifications are suitable and sufficient for all applications and reasonably foreseeable uses of the components or systems.

Term definition: User in the sense of user, installer, installation company.

Preface

Dear Customer,

Thank you for purchasing a Becker Avionics product. We are pleased that you have chosen our product and we are confident that it will meet your expectations.

For development and manufacturing of our product, the guidelines for highest quality and reliability have been borne in mind, supplemented by selection of high-quality material, responsible production and testing in accordance to the standards.

Our competent customer support department will respond on any technical question you may have. Please do not hesitate to contact us at any time.

VHF-Transceivers 6200 Series*



AR6201, AR6211
(Single Block Transceiver)



RCU6201, RCU6211
(Remote Control Unit)

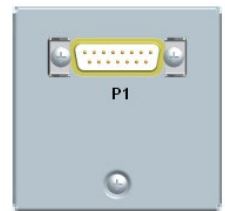

AR6203, AR6213
(Single Block Transceiver)



RT6201, RT6211
(Remote-Controlled Transceiver)

* design depends on variant

* Some figures in this manual are for basic understanding and can be different to the actual design.

List of Effective Pages and Changes

Only technical relevant modifications are described in this table.

Document:	DV14307.03 / issue 06	Article Number 0638.404-071	
Cover Page	09/2020		
Introduction	09/2020		
Chapter 1 – 4	09/2020		
Issue	Page No.:	Section / Chapter	Description
06	1-142	all	Updated: Editorial adjustments.
	--	all	Added: New device variants.
	--	all	Updated: Device drawings.
	--		
	--		
	--		
	--		
	--		
	--		
	--		
	--		
	--		
	--		
	--		
	--		
	--		

© by Becker Avionics GmbH / all rights reserved

Table of Contents

1	General Description	13
1.1	Introduction	14
1.2	Purpose of Equipment.....	15
1.3	General Notices	15
1.4	Variants Overview	16
1.4.1	Software Status.....	18
1.4.2	Short Description	19
1.5	Scope of Functionality.....	22
1.5.1	Frequency Indication.....	22
1.5.2	Audio Outputs	22
1.5.3	Mike Inputs.....	22
1.5.4	AF Auxiliary Input.....	22
1.5.5	Sidetone.....	23
1.5.6	Squelch Operation	23
1.5.7	Memory Channels.....	23
1.5.8	Scan Mode.....	23
1.5.9	Illumination.....	23
1.5.10	LOW BATT Indication	23
1.5.11	Emergency Operation	23
1.5.12	Built-In Tests	23
1.5.13	Tandem Operation	24
1.5.14	Intercom Operation	24
1.5.15	Configuration Setup	24
1.5.16	Service Mode	24
1.6	Safety-Conscious Utilization	25
1.7	Restriction for Use.....	25
1.8	Technical Data	26
1.8.1	General Characteristics	26
1.8.2	Typical Power Consumption	27
1.8.3	Receiver Data AR62XX, RT62X1	27
1.8.4	Transmitter Data AR62XX, RT62X1	28
1.8.5	Emergency Operation	29
1.8.6	Dimensions & Weight.....	29
1.8.7	Software.....	30
1.8.8	Hardware	30
1.8.9	Continued Airworthiness.....	30
1.8.10	Environmental Conditions AR62X1-(X1X), RT62X1-(X1X)	31
1.8.11	Environmental Conditions AR62X1-(X2X), RT62X1-(X2X)	32
1.8.12	Environmental Conditions AR62X3-().....	33
1.8.13	Environmental Conditions RCU62X1-().....	35
1.8.14	Certifications	36
1.9	Order Code	40
1.9.1	Devices 62XX Series	40
1.9.2	Accessories.....	41
1.9.3	Spare Parts.....	42
1.9.4	Documentation.....	42
2	Installation.....	43
2.1	Packaging, Transport, Storage	44
2.2	Device Assignment	45
2.2.1	Scope of Delivery.....	45
2.2.2	State of Delivery.....	45
2.2.3	Additional Required Equipment	45
2.2.4	Registration of the Device.....	45
2.2.5	Type Plate.....	46
2.2.6	Software/Firmware Status – Functionality	46
2.3	Installation Requirements.....	47
2.3.1	Installation in the Avionic Compartment	48
2.3.2	Cockpit Panel Installation	49
2.3.3	Rear Panel Installation.....	49
2.4	Dimensions	50
2.4.1	AR6201, AR6211	50

2.4.2	AR6203, AR6213	51
2.4.3	RCU62X1	52
2.4.4	RT62X1	53
2.4.5	RT62X1 with MK6201	54
2.4.6	Mounting kit - MK6201	55
2.4.7	Mounting kit - MK6403-1	56
2.5	Connector Pin Assignments	57
2.5.1	Device Connectors (AR62XX, RT62X1)	57
2.5.2	Antenna Connector (AR62XX, RT62X1).....	57
2.5.3	Grounding Bolt (AR62XX, RT62X1).....	57
2.5.4	Inputs / Outputs (AR62XX, RT62X1)	60
2.5.5	Device Connector (RCU62X1).....	64
2.5.6	Inputs / Outputs (RCU62X1)	65
2.6	Installation and Configuration	66
2.6.1	General Requirements	66
2.6.2	Customized Applications.....	66
2.6.3	Antenna Installation.....	66
2.7	Configuration Setup.....	69
2.7.1	Configuration Interface.....	69
2.7.2	Start Configuration Setup.....	69
2.7.3	Volume Adjustment (VU Meter)	70
2.7.4	Device Info	71
2.7.5	Dimming, Brightness	72
2.7.6	Illumination Curve	73
2.7.7	Memory Options.....	74
2.7.8	Modification, Battery.....	74
2.7.9	Configuration	75
2.7.10	Auxiliary Audio Input	76
2.7.11	IN/OUT CFG1	76
2.7.12	IN/OUT CFG2	78
2.7.13	Standard Microphone 1.....	79
2.7.14	Standard Microphone 2.....	80
2.7.15	Standard Microphone 3.....	81
2.7.16	Dynamic Microphone	82
2.7.17	Speaker.....	82
2.7.18	Squelch	83
2.7.19	Scan Hold Time.....	83
2.7.20	Sidetone	83
2.7.21	Erase Memory.....	84
2.7.22	Fail List.....	85
2.7.23	Recall Default Settings.....	85
2.8	Factory Default Settings	86
2.9	Aircraft Wiring.....	88
2.9.1	Electrical Bonding and Grounding	88
2.9.2	Single Seat Glider	88
2.9.3	Installation with RT62X1 and RCU62X1	91
2.9.4	Twin Seat with RT62X1 (Tandem-Installation)	92
2.9.5	Twin Seat Motor Glider	94
2.9.6	General Aviation (GA) Aircraft.....	96
2.9.7	Individual Dual Headset Installation (two IC Circuits).....	98
2.9.8	Twin Seat with AR62XX (Tandem-Installation).....	100
2.9.9	Four Seat Installation (no Tandem)	102
2.9.10	Installation in Aircraft with Intercom System	104
2.9.11	Recommendation for the Installation of two Transceivers in one Aircraft.....	107
2.9.12	Cable Harness	111
2.10	Retrofitting - AR4201 with AR62X1	113
2.10.1	Wiring AR4201 - AR62X1	113
2.10.2	Dynamic Microphone Input	114
2.10.3	Temperature Sensor	115
2.10.4	RS232 Interface	115
2.10.5	AFCU/AGC/AFWB	115
2.10.6	CPIN (if Installed).....	115
2.10.7	+13.75 V (AR4201) - PWR_EVAL (AR62X1)	115

2.11	Post Installation Check.....	116
2.11.1	Mechanical Installation and Wiring Check.....	116
2.11.2	Power Supply.....	116
2.11.3	Receiver / Transmitter Operation.....	116
2.11.4	Antenna Check.....	116
2.11.5	Interference Check.....	117
2.11.6	Flight Test Check.....	118
2.12	Error / Failure Indication.....	118
2.13	Troubleshooting.....	119
3	Operation.....	121
3.1	General.....	121
3.1.1	Registration of the Device.....	121
3.2	Device Description.....	123
3.2.1	Device Assignment.....	123
3.2.2	Packing, Transport, Storage.....	123
3.2.3	Scope of Delivery.....	123
3.2.4	State of Delivery.....	123
3.2.5	Type Plate.....	123
3.2.6	Controls and Indications.....	124
3.3	Start-Up.....	125
3.4	Receive Mode.....	126
3.5	Transmit Mode.....	126
3.6	Frequency Selection Modes.....	127
3.6.1	Standard Mode.....	128
3.6.2	Direct Tune Mode.....	129
3.6.3	Channel Mode.....	130
3.6.4	Frequency Storage Functions.....	131
3.6.5	Automatic Storage Function.....	133
3.6.6	Scan Mode.....	134
3.7	Squelch (SQL).....	134
3.8	RX Field Strength Indication.....	135
3.9	Channel Spacing.....	135
3.10	Auxiliary Audio Input (AUX INPUT).....	135
3.11	Intercom Operation.....	136
3.11.1	Pilot Circuit and Passenger Circuit.....	136
3.11.2	Intercom Operation started with VOX.....	136
3.11.3	Intercom Operation started with an Intercom Switch.....	137
3.12	VOX & Speaker Operation.....	137
3.13	Menus.....	137
3.13.1	User Menu.....	138
3.13.2	Intercom Menu.....	139
3.14	Read Out and Reset Error/Failure Flags.....	140
3.15	Warning and Failure Indications.....	140
3.16	Contact Data.....	141
4	Index.....	142

List of Figures

Some figures in this manual are for basic understanding and can be different to the actual design.

Figure 1: Example: Device Combinations	19
Figure 2: AR6201, AR6211 Single Block Transceiver	20
Figure 3: AR6203, AR6213 Single Block Transceiver	20
Figure 4: RT6201, RT6211 Remote-Controlled Transceiver	21
Figure 5: RCU6201, RCU6211 Remote Control Unit	21
Figure 6: Type Plate (example)	46
Figure 7: RT62X1, MK6201-(10) Installation	48
Figure 8: MK6403-1: Cockpit Panel Installation	49
Figure 9: AR62X1, RCU62X1 (front view)	49
Figure 10: Drilling Template -Rear-Panel Installation	49
Figure 11: Dimensions - AR6201, AR6211	50
Figure 12: Dimensions - AR6203, AR6213	51
Figure 13: Dimensions - RCU62X1	52
Figure 14: Dimensions - RT62X1	53
Figure 15: Dimensions - RT62X1 with mounting kit MK6201	54
Figure 16: Dimensions - Mounting kit MK6201 (for RT62X1)	55
Figure 17: Dimensions - Mounting kit MK6403-1 (for AR62X3)	56
Figure 18: AR62X1, RT62X1 – Connector Layout	57
Figure 19: AR62X3 – Connector Layout	57
Figure 20: RCU62X1 – Connector Layout	64
Figure 21: "PASSWORD"	69
Figure 22: "DECIVE INFO"	69
Figure 23: Wiring - Single Seat Glider	89
Figure 24: Wiring - Single Seat Glider 5-pol DIN Jack	90
Figure 25: Wiring - Installation with RT62X1 and RCU62X1	91
Figure 26: Wiring - Twin Seat with RT62X1 (Tandem-Installation)	93
Figure 27: Wiring - Twin Seat Motor Glider	95
Figure 28: Wiring - General Aviation Aircraft (with Standard Hand Mikes, Earphones and Speaker)	97
Figure 29: Wiring - Individual Dual Headset Installation (two IC Circuits)	99
Figure 30: Wiring - Twin Seat with AR62XX (Tandem-Installation)	101
Figure 31: Wiring - Four Seat Installation (no Tandem)	103
Figure 32: Wiring - Aircraft with Intercom System (Unbalanced)	105
Figure 33: Wiring - Aircraft with Intercom System (Balanced)	106
Figure 34: Cable Harness 1K065	112
Figure 35: AR62X1 with Wiring Interface for AR4201	114
Figure 36: Modified Dynamic Microphone Wiring for AR62X1	114
Figure 37: Controls and Indicators	124

List of Abbreviations

List of Abbreviations

6200	Becker Avionics Compact Line Product Series, Light & Sport Aviation
AF	Audio Frequency
AR	Airborne Radio
ATT	Attenuation
AUX	Auxiliary
AWG	American Wire Gauge
BNC	Bayonet Neill Concelman
CBIT	Continuous Built-In Test
CFG	Configuration
CH	Channel, Control Head
CM	Chassis Module
COM	Communication
EASA	European Aviation Safety Agency
ELT	Emergency Locator Transmitter

List of Abbreviations

EMI	Electro Magnetic Interference
ETSO	European Technical Standard Order
EUROCAE	European Organization for Civil Aviation Equipment
FAA	Federal Aviation Administration
GND	Ground (Aircraft Ground)
GPS	Global Positioning System
HIRF	High Intensity Radiated Fields
HMI	Human Machine Interface
I&O	Installation & Operation
IC	Intercom
LCD	Liquid Crystal Display
M&R	Maintenance & Repair
MFD	Multi-Function Display
N/A	Not Applicable
NAV	Navigation
PBIT	Power-On Built In Test
PTT	Push To Talk
PWR	Power
RCU	Remote Control Unit
RSSI	Received Signal Strength Indication
RT	Remote(-controlled) Transceiver
RX	Receive
SPKR	Speaker (Loudspeaker)
SQL	Squelch
SRC	Source
SW	Software
TF	TufLok®, self-locking screws and threads
TSO	Technical Standard Order
TX	Transmit
VDC	Voltage Direct Current
VHF	Very High Frequency
VOX	Voice Operated Switch
VSWR	Voltage Standing Wave Ratio
VU	Volume Unit

Units**Units**

A	Ampere
mA	Milliampere
°C	Degree Celsius
cm	Centimeter
dBm	Power Ratio in Decibel referenced to 1 mW

Units

dB	Decibel
g	Gram
kg	Kilogram
kHz	Kilohertz
km/h	Kilometer Per Hour
kts	Knots
MHz	Megahertz
mm	Millimeter
Nm	Newton Meter
NM	Nautical Mile (1NM = 1852 m)
Ohm (Ω)	Resistance
s	Second
V	Volt
mV	Millivolt
W	Watt
mW	Milliwatt
"	Inch
°	Angular degree

General Safety Definitions

 **DANGER** Indicates a hazardous situation which, if not prevented, will result in death or serious injury.

 **WARNING** Indicates a hazardous situation which, if not prevented, could result in death or serious injury.

 **CAUTION** Indicates a hazardous situation which, if not prevented, could result in minor or moderate injury.

 **NOTICE** Is used to address practices not related to physical injury.

 **SAFETY INSTRUCTIONS** Safety instructions (or equivalent) signs indicate specified safety-related instructions or procedures.

Disposal

⚠ CAUTION | The packaging material is inflammable, by burning, toxic fumes may develop.

This product contains materials that fall under the special disposal regulation. We recommend the disposal of such materials in accordance with the current environmental laws.

- Dispose circuit boards by a technical waste dump which is approved to take on e.g. electrolytic aluminium capacitors. Do under no circumstances dump the circuit boards with normal waste dump.

Warranty Conditions

⚠ CAUTION | The device(s) may be installed on an aircraft only by an approved aeronautical company (e.g. Part 145) which shall also examine the installation.

Any change made by the user excludes any liability on our part (excluding the work described in this manual).

- The device must not be opened.
- Do not make any modifications to the device, except for those described in the manual.
- Make connections to the inputs, outputs and interfaces only in the manner described in the manual.
- Install the devices according to the instructions.
We cannot give any guarantee for other methods.

Conditions of Utilization

With this device you bought a product which was manufactured and tested before delivery with the utmost care.

Please take your time to read the instructions which you ought to follow closely during installation and operation.

Otherwise all claims under the warranty will become void and a decreased service life or even damages must be expected.

⚠ CAUTION | The user is responsible for protective covers and/or additional safety measures in order to prevent damages to persons and electric accidents.

Additional Conditions of Utilization

Please refer to "Safety-Conscious Utilization", page 25.

Non-Warranty Clause

We checked the contents of this publication for compliance with the associated hard and software. We can, however, not exclude discrepancies and do therefore not accept any liability for the exact compliance. The information in this publication is regularly checked, necessary corrections will be part of the subsequent publications.

Blank Page

1 General Description

In this chapter you can read about:

1.1	Introduction	14
1.2	Purpose of Equipment.....	15
1.3	General Notices	15
1.4	Variants Overview	16
1.4.1	Software Status.....	18
1.4.2	Short Description	19
1.5	Scope of Functionality.....	22
1.5.1	Frequency Indication.....	22
1.5.2	Audio Outputs	22
1.5.3	Mike Inputs.....	22
1.5.4	AF Auxiliary Input.....	22
1.5.5	Sidetone.....	23
1.5.6	Squelch Operation	23
1.5.7	Memory Channels.....	23
1.5.8	Scan Mode	23
1.5.9	Illumination.....	23
1.5.10	LOW BATT Indication	23
1.5.11	Emergency Operation	23
1.5.12	Built-In Tests	23
1.5.13	Tandem Operation	24
1.5.14	Intercom Operation	24
1.5.15	Configuration Setup	24
1.5.16	Service Mode	24
1.6	Safety-Conscious Utilization	25
1.7	Restriction for Use.....	25
1.8	Technical Data	26
1.8.1	General Characteristics	26
1.8.2	Typical Power Consumption	27
1.8.3	Receiver Data AR62XX, RT62X1	27
1.8.4	Transmitter Data AR62XX, RT62X1	28
1.8.5	Emergency Operation	29
1.8.6	Dimensions & Weight.....	29
1.8.7	Software.....	30
1.8.8	Hardware	30
1.8.9	Continued Airworthiness.....	30
1.8.10	Environmental Conditions AR62X1-(X1X), RT62X1-(X1X)	31
1.8.11	Environmental Conditions AR62X1-(X2X), RT62X1-(X2X)	32
1.8.12	Environmental Conditions AR62X3-().....	33
1.8.13	Environmental Conditions RCU62X1-().....	35
1.8.14	Certifications	36
1.9	Order Code	40
1.9.1	Devices 62XX Series	40
1.9.2	Accessories.....	41
1.9.3	Spare Parts	42
1.9.4	Documentation.....	42

This manual describes the Becker Avionics VHF Transceivers of the 6200 series. The type plate on your device shows the part number for identification purposes (see "Type Plate", page 46).

Before starting operation of the device(s) please read this manual carefully, with particular attention to the description referring to your device(s).

Introduction

1.1 Introduction

The technical information in this document applies to the products and variants of the VHF Transceiver of the 6200 series.

Details for variants please see "Variants Overview" page 16.

- For further description we use also short forms.
 - 6200 series in general for the device family.
 - AR62X1 for: AR6201, AR6211, (Single Block Transceiver).
 - AR62X3 for: AR6203, AR6213 (Single Block Transceiver).
 - AR62XX for: AR6201, AR6211, AR6203, AR6213 (Single Block Transceiver).
 - RT62X1 for: RT6201, RT6211 (Remote-Controlled Transceiver).
 - RCU62X1 for: RCU6201, RCU6211 (Remote Control Unit).
- If a description refers to only one of the product variants is it specified.

The manuals "Maintenance and Repair" (**M&R**), "Installation and Operation (**I&O**) and "Operation Instructions" (**OI**) contain the sections:

Section	DV14307.04 M&R	DV14307.03 I&O	- OI
General	X	X	-
Installation	X	X	-
Operation	X	X	X
Theory of Operation	X	N/A	N/A
Maintenance and Repair	X	N/A	N/A
Illustrated Parts List	X	N/A	N/A
Modification and Changes	X	N/A	N/A
Circuit Diagrams	X	N/A	N/A
Certifications	X	N/A	N/A
Attachments	X	N/A	N/A

1.2 Purpose of Equipment

The 6200 series are a modern family of communication equipment.

Features:

- The sensitive receiver obeys the most recent requirements of ED-23C.
 - It includes the ability to work in the offset-carrier (climax) operation in 25 kHz and 8.33 kHz channel spacing.
- The devices are for voice communication between aircraft or between aircraft and ground. The devices use the VHF-band between 118.000...136.9916 MHz respectively 136.9750 MHz with a selectable channel spacing of 8.33 or 25 kHz.
- High efficiency transmitter delivers more than 10 W modulated, or un-modulated, output power at 28 V supply voltage, or 6 W at 12 V supply voltage.
- The devices are made for applications where low power consumption is required e.g. for gliders and leisure aircraft and balloons.
- The devices can operate from standard 14 VDC and 28 VDC installations and from 12 VDC or 24 VDC batteries.
- The receiver includes SCAN (dual watch) mode. This is for monitoring of two different VHF frequency channels at the same time while the communication on the active frequency.
- The squelch function prevents unwanted audio noise.
- The AUX audio input for connection of additional audio devices like navigation receiver, warning-tone generator, or MP3 music player.
- The tandem function for a synchronized operation of two controllers.
- The intercom function is for voice communication between aircraft crew and passengers.
- The extended built-in intercom can work as:
 - 4-way intercom with isolation mode – passengers could continue conversation or listen to the music from a MP3 player at the same time while pilots talk through intercom or communicate with the tower.
 - 2-way intercom for tandem operation – pilot and co-pilot have different controllers and can control their individual audio parameters, like volume or VOX. This mode is preferred for training due to full synchronization of LCD contents.
- The devices have a non-volatile memory for the storage of:
 - 99 channels for storage of VHF frequencies with customized labels.
 - 9 recently selected VHF frequencies.

1.3 General Notices

The word "frequency" is also used in the sense of "channel name", as defined in EUROCAE, document ED 23C chapter 1.3.2, Volume II.

In this document the word "memory channel" or "channel" is also used in the sense of a memory position identified by a channel number, where a frequency may be stored for later use.

1.4 Variants Overview

AR 62X X - (X X X)

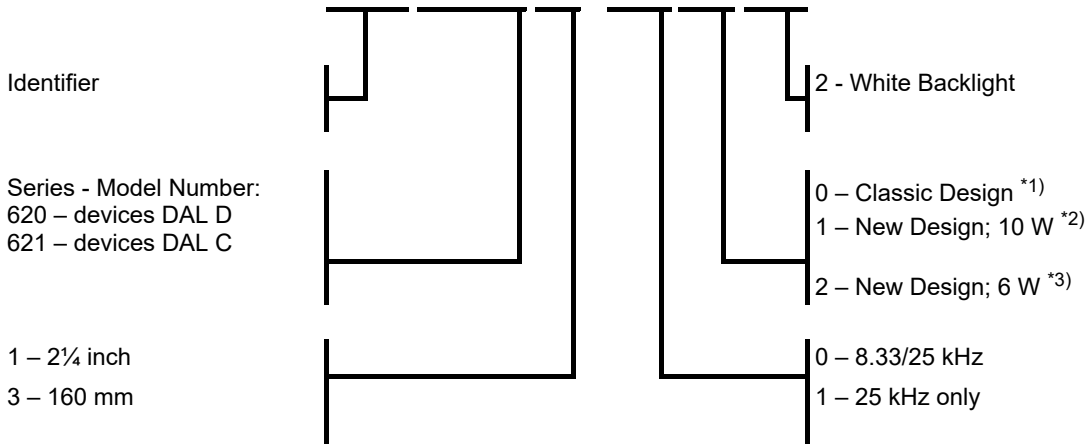

Notice: This manual is not for the -(X0X) variants.

*¹⁾ TX = 6 W; 2-seat IC

*²⁾ TX = 10 W; 4 seat IC; Tandem capability; lower mounting depth.

*³⁾ TX = 6 W; 4 seat IC; Tandem capability; lower mounting depth.

AR6201, AR6211 Single Block Transceiver (available variants)

Part Number	Article-No	8.33 kHz Mode	25 kHz Mode	Transmit PWR
AR6201-(012)	0631.418-910	yes	yes	≥ 6 W @ 14 V / 10 W @ 28 V
AR6201-(022)	0636.339-910	yes	yes	≥ 6 W @ 14 V / 6 W @ 28 V
AR6201-(112)	0631.434-910	no	yes	≥ 6 W @ 14 V / 10 W @ 28 V
AR6201-(122)	0636.355-910	no	yes	≥ 6 W @ 14 V / 6 W @ 28 V
AR6211-(012)	0662.410-910	yes	yes	≥ 6 W @ 14 V / 10 W @ 28 V
AR6211-(022)	0662.437-910	yes	yes	≥ 6 W @ 14 V / 6 W @ 28 V
AR6211-(112)	0662.429-910	no	yes	≥ 6 W @ 14 V / 10 W @ 28 V
AR6211-(122)	0662.445-910	no	yes	≥ 6 W @ 14 V / 6 W @ 28 V

AR6203, AR6213 Single Block Transceiver (available variants)

Part Number	Article-No	8.33 kHz Mode	25 kHz Mode	Transmit PWR
AR6203-(012)	0630.993-910	yes	yes	≥ 6 W @ 14 V / 10 W @ 28 V
AR6203-(022)	0636.371-910	yes	yes	≥ 6 W @ 14 V / 6 W @ 28 V
AR6203-(112)	0631.566-910	no	yes	≥ 6 W @ 14 V / 10 W @ 28 V
AR6203-(122)	0636.398-910	no	yes	≥ 6 W @ 14 V / 6 W @ 28 V
AR6213-(012)	0662.518-910	yes	yes	≥ 6 W @ 14 V / 10 W @ 28 V
AR6213-(022)	0662.534-910	yes	yes	≥ 6 W @ 14 V / 6 W @ 28 V
AR6213-(112)	0662.526-910	no	yes	≥ 6 W @ 14 V / 10 W @ 28 V
AR6213-(122)	0662.542-910	no	yes	≥ 6 W @ 14 V / 6 W @ 28 V

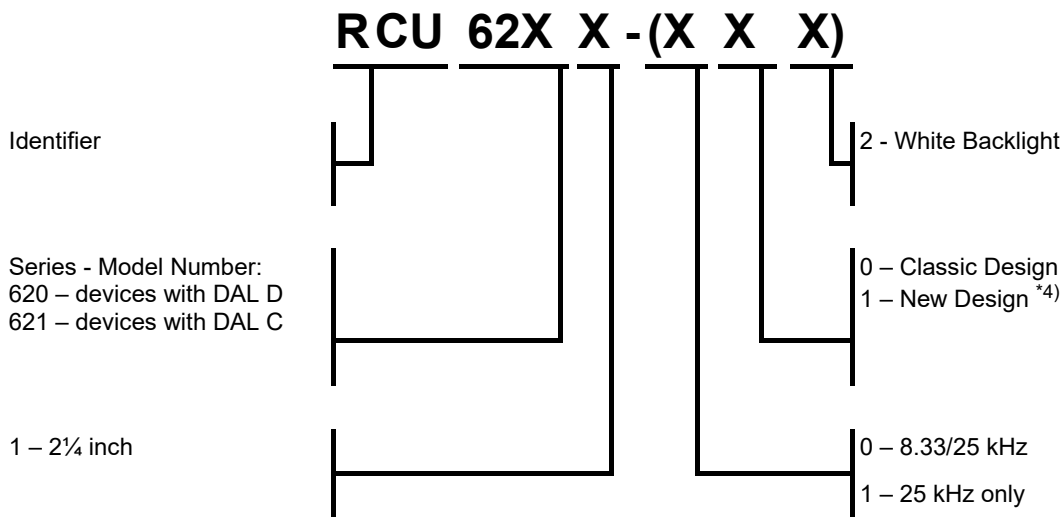

Notice: This manual is not for the -(X0X) variants.

*4) lower mounting depth.

RCU6201, RCU6211 Remote Control Unit (available variants)

Part Number	Article-No	8.33 kHz Mode	25 kHz Mode	Transmit PWR
RCU6201-(012)	0631.469-910	yes	yes	N/A
RCU6201-(112)	0631.485-910	no	yes	N/A
RCU6201-(012)	0662.453-910	yes	yes	N/A
RCU6201-(112)	0662.461-910	no	yes	N/A

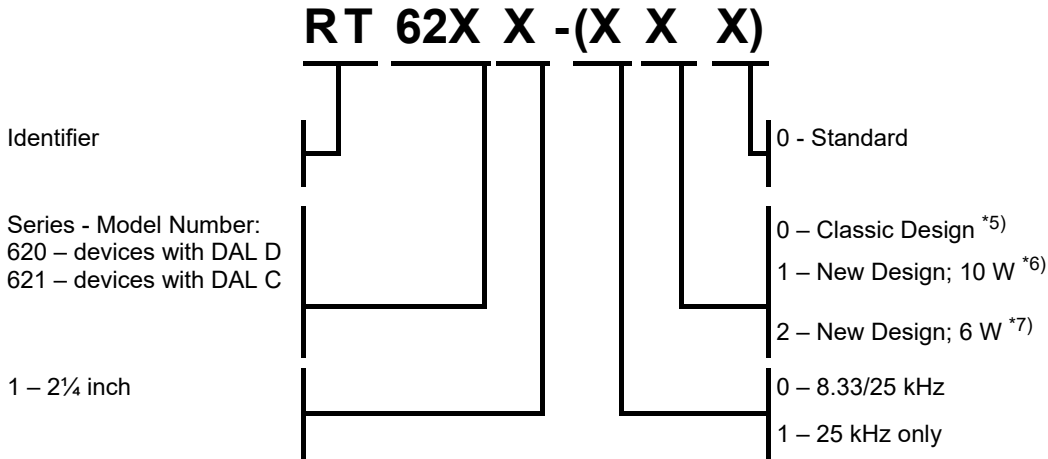

*5) TX = 6 W; 2-seat IC

*6) TX = 10 W; 4 seat IC; Tandem capability; lower mounting depth.

*7) TX = 6 W; 4 seat IC; Tandem capability; lower mounting depth.

RT6201, RT6211 Remote Transceiver (available variants)

Part Number	Article-No	8.33 kHz Mode	25 kHz Mode	Transmit PWR
RT6201-(010)	0631.442-910	yes	yes	≥ 6 W @ 14 V / 10 W @ 28 V
RT6201-(020)	0636.312-910	yes	yes	≥ 6 W @ 14 V / 6 W @ 28 V
RT6201-(110)	0638.609-910	no	yes	≥ 6 W @ 14 V / 10 W @ 28 V
RT6201-(120)	0638.617-910	no	yes	≥ 6 W @ 14 V / 6 W @ 28 V
RT6211-(010)	0662.471-910	yes	yes	≥ 6 W @ 14 V / 10 W @ 28 V
RT6211-(020)	0662.488-910	yes	yes	≥ 6 W @ 14 V / 6 W @ 28 V

1.4.1 Software Status

Descriptions see "Software/Firmware Status – Functionality", page 46.

1.4.2 Short Description



AR6201, AR6211



RCU62X1



AR6203, AR6213



RCU62X1

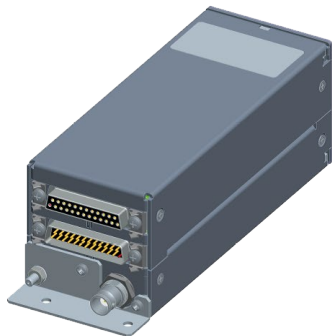

RT62X1



RCU62X1

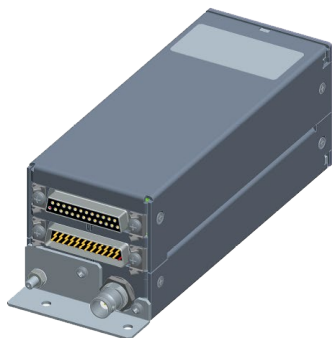

RT62X1



up to two RCU62X1

Figure 1: Example: Device Combinations

A RCU62X1 (Remote Control Unit) or a third-party controller is necessary to control the RT62X1.

1.4.2.1 AR62X1 Single Block Transceiver

- The AR62X1 is a single block device made for operation in a cockpit environment for general aviation aircraft and helicopters.
- All controls and indicators are on the front panel. The equipment connectors and the antenna socket are at the rear side of the device.
- Installation with four screws (rear panel installation). The dimensions agree with the standard instrument diameter of 58 mm (2¼ inch).



Figure 2: AR6201, AR6211 Single Block Transceiver

1.4.2.2 AR62X3 Single Block Transceiver

- The AR62X3 is a single block device made for operation in a cockpit environment for general aviation aircraft and helicopters.
- All controls and indicators are on the front panel. The equipment connectors and the antenna socket are at the rear side of the device.
- Installation in the cockpit panel of an aircraft with a mounting kit MK6403-1 (see "Mounting kit - MK6403-1", page 56). The dimensions agree with the state-of-the-art 160 mm (6.3").



Figure 3: AR6203, AR6213 Single Block Transceiver

1.4.2.3 RT62X1 Remote-Controlled Transceiver

- The RT62X1 is a remote-controlled device. It does not include a control panel.
- It can receive commands and supplies data through the RCU62X1 (Remote Control Unit) or a third-party controller.
- It is made for installation in avionic compartment for general aviation aircraft and helicopters.
To obey the conditions for certification, use the mounting kit MK6201-(010).

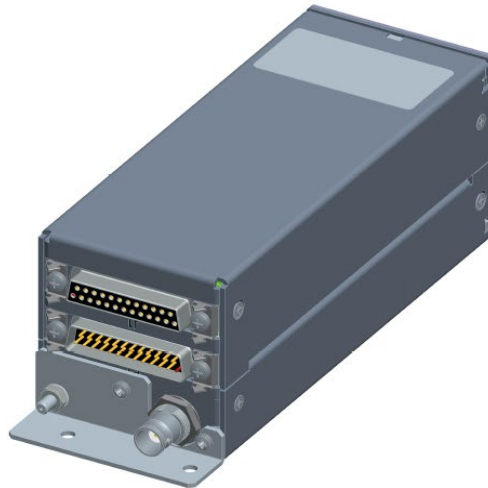

Figure 4: RT6201, RT6211 Remote-Controlled Transceiver

1.4.2.4 RCU62X1 Remote Control Unit

- The RCU62X1 is a compact and lightweight device, made for operation in a cockpit environment for general aviation aircraft and helicopters.
- All controls and indicators are on the front panel.
The equipment connector is at the rear side of the device.
- Installation with four screws (rear panel installation).
The dimensions agree with the standard instrument diameter of 58 mm (2¼ inch).

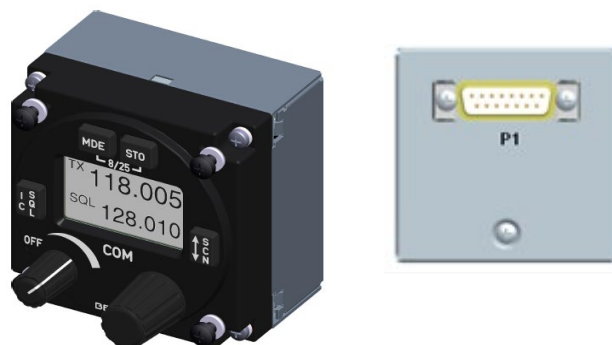

Figure 5: RCU6201, RCU6211 Remote Control Unit

1.5 Scope of Functionality

1.5.1 Frequency Indication

- A liquid crystal display (LCD) do the frequency indication.
- The required operating frequency is selectable with a rotary encoder.
- The relation between the real operating frequency and the shown frequency complies with the standards (ED-23C, chapter 1.3.2).

Operating frequency MHz	Channel spacing kHz	Frequency shown on the display	
		8.33 + 25 kHz mixed mode	25 kHz mode
118.0000	25	118.000	118.00
118.0000	8.33	118.005	N/A
118.0083	8.33	118.010	N/A
118.0166	8.33	118.015	N/A
118.0250	25	118.025	118.02
etc.	etc.	etc.	etc.
136.9750	25	136.975	136.97
136.9750	8.33	136.980	N/A
136.9833	8.33	136.985	N/A
136.9916	8.33	136.990	N/A

1.5.2 Audio Outputs

The transceivers have four configurable outputs:

- Headphone 1 output:
 - Rated output power is 300 mW into 75 Ω .
- Headphone 2 output:
 - Rated output power is 200 mW into 75 Ω .
- Speaker output:
 - Rated output power is 4 W into 4 Ω .
- LINE-OUT output:
 - For ground station use only.

Notice: **Headphone 2 and the speaker output cannot be active at the same time.**

1.5.3 Mike Inputs

- The transceivers have four microphone inputs:
 - Standard microphone input 1 (STD_MIKE1)
 - Standard microphone input 2 (STD_MIKE2)
 - Standard microphone input 3 (STD_MIKE3)
 - Dynamic microphone input (DYN_MIKE)
- Each input can operate with one single microphone or with two microphones of the same type connected in parallel.

1.5.4 AF Auxiliary Input

- The AF auxiliary input is the interface to connect an external audio source (e.g. other radio services, music-player).
 - The interconnection of multiple external audio sources on this port make an additional external decoupling/isolation resistor necessary.
 - The external audio is audible only when the transceiver is in receiving mode.
 - The individual audio volume is set directly at the external equipment.

1.5.5 Sidetone

- The sidetone is available on the headphone output during transmission.
- The sidetone volume depends on to the intercom volume adjustment.

1.5.6 Squelch Operation

- The squelch (muting) circuit suppresses signals with strong signal noise.
- There are two kinds of squelch methods implemented, carrier- and noise-squelch.
 - The carrier-squelch depends on the signal strength and is adjustable in configuration setup.
 - The noise-squelch depends on the noise level and is adjustable in the user menu.

1.5.7 Memory Channels

- You can store 99+9 frequencies.
 - The user can give a defined text label to each stored frequency.
 - The last recently used 9 (active) frequencies are stored automatically as "LAST" channels.

1.5.8 Scan Mode

- The scan mode is a dual watch function.
 - The device monitors frequencies on two different channels, active & preset frequency at the same time.
 - The signal of the active frequency is always audible it has priority at all times.

1.5.9 Illumination

- The illumination of LCD and keys is controlled from the front panel with the user menu or externally with the dimming input lines.
- If external dimming is selected, the illumination curve (brightness to voltage relation) is adjustable in the configuration setup.

1.5.10 LOW BATT Indication

- The transceiver monitors the power supply voltage.
 - If the power supply voltage is less than the adjusted threshold, the display shows the message "LOW BATT".
 - If the power supply voltage decreases further, an emergency operation mode starts.

1.5.11 Emergency Operation

- If the power supply voltage is < 10.25 V, the device continues operation with decreased performance.
- If the power supply voltage is < 9.0 V, the device turns off automatically.

1.5.12 Built-In Tests

Power-On Built-In Test

- After power-on, the device starts a self-test (PBIT).
 - The display shows the message "WAIT" and the software versions of the control head and the chassis module.
 - If there is an error the display shows the message "FAILURE, push any key".
 - If there is no error the transceiver changes to the last active mode before power off.

Continuous Built-In Test

- During normal operation, a self-test (CBIT) permanently examine the correct operation of the device.
 - The display shows an error message, if there is an error during CBIT.

1.5.13 Tandem Operation

- The tandem mode is for operation of two controllers at the same time.
- The controllers synchronizing each other, both show the same information.

1.5.14 Intercom Operation

- The built-in intercom circuit is for internal communication between pilots and passengers with connected headsets.
- The 62XX system has two intercom circuits:
 - "Front row" and "Back row".
 - You can connect a maximum of four headsets, e.g. the pilot & copilot headsets to the first circuit and two passenger headsets to second circuit.

1.5.15 Configuration Setup

The configuration setup is for the configuration of installation and device parameters such as mike sensitivity, mike type selection, speaker enable/disable and other parameters.

1.5.16 Service Mode

- The service mode is a special configuration mode.
- You can get access to the service mode through the RS422 interface with a proprietary serial data communication protocol.
- This mode is for use by authorized maintenance organizations only.

1.6 Safety-Conscious Utilization

For safe operation of the product the notices have to be obeyed:

⚠ CAUTION

The device(s) may be installed on an aircraft only by an approved aeronautical company (e.g. Part 145) which shall also examine the installation.

SAFETY INSTRUCTIONS

- The installation of the device into an aircraft may be carried out only by an authorized installation company. The country regulations always have to be obeyed.
- Use the product only in the specified conditions, see "Technical Data", page 26.
- Power supply:
 - Do not connect the device to AC sources.
 - Make sure that the device is connected to the mandatory DC source, see "Technical Data", page 26.
 - Do not connect the device with reversed polarity to the DC source.
- Circuit breaker:
 - Use the recommended fuses in the power supply line for the protection of the application, see "Technical Data", page 26.

NOTICE

Cleaning:

- Do not use aggressive cleaning agents e.g. Acetone.
 - These cleaning agents can cause damages.

NOTICE

Excessive pulses on the DC bus of the aircraft may cause damage on electrical circuits of any installed instrument.

Do not turn on the device during engine start or shutdown.

1.7 Restriction for Use

SAFETY INSTRUCTIONS

The product is to be used inside the declared limits.

Technical Data

1.8 Technical Data**1.8.1 General Characteristics**

	Specification	Variants
Nominal supply voltage	11.0...30.3 V	all variants
Extended supply voltage	10.25...32.2 V	all variants
Emergency operation	9.0...10.25 V	all variants
Dimming control	0...14 V or 0...28 V	all variants
Frequency	118.000...136.975 MHz	-(1XX) variant
	118.000...136.9916 MHz	-(0XX) variant
Channel spacing	25 kHz	-(1XX) variant
	8.33/25 kHz	-(0XX) variant
Number of channels	25 kHz 760	-(1XX) variant
	8.33/25 kHz 2280/760	-(0XX) variant
Storage Temperature	-55...+85 °C	all variants
Operating Temperature	-20...+55 °C	AR62XX, RCU62
	-40...+55 °C	RT62
	short-time +70 °C	all variants
Operating Altitude	35 000 ft	
Vibration	Category S (Curve M) + Category U (Curve G)	

Recommended external fuse protection in the application	depends on device see "Aircraft Wiring" from page 13.
---	---

1.8.2 Typical Power Consumption

	AR62XX -(X2X) 6 W	AR62XX -(X1X) 10 W	RT62X1 -(X2X) 6 W	RT62X1 -(X1X) 10 W	RCU62X1 -(XXX)
Power "off" @ 12 VDC	≤ 0.10 mA	≤ 0.10 mA	≤ 0.10 mA	≤ 0.10 mA	≤ 0.10 mA
Power "off" @ 27.5 VDC	≤ 0.10 mA	≤ 0.10 mA	≤ 0.10 mA	≤ 0.10 mA	≤ 0.10 mA
Reception stand-by mode @ 13.75 VDC, panel backlight off	≤ 140 mA	≤ 140 mA	≤ 120 mA	≤ 120 mA	≤ 20 mA
Reception stand-by mode @ 27.5 VDC, panel backlight off	≤ 80 mA	≤ 80 mA	≤ 80 mA	≤ 80 mA	≤ 20 mA
Transmit mode (in %) @ 13.75 VDC, VSWR=1:1	1.8 A at 70% 1.5 A at 0%	-	1.8 A at 70% 1.5 A at 0%	-	≤ 20 mA
Transmit mode (in %) @ 27.5 VDC, VSWR=1:1	1.2 A at 70% 1.0 A at 0%	1.4 A at 70% 1.0 A at 0%	1.2 A at 70% 1.0 A at 0%	1.4 A at 70% 1.0 A at 0%	≤ 20 mA
Absolute maximum current @ 13.75 VDC, VSWR=3:1	≤ 3 A	-	≤ 2,9 A	-	≤ 20 mA
Absolute maximum current @ 27.5 VDC, VSWR=3:1	≤ 2 A	≤ 2.5 A	≤ 1.9 A	≤ 2.4 A	≤ 20 mA

1.8.3 Receiver Data AR62XX, RT62X1

Receiver Data AR62XX, RT62X1	
Sensitivity	≤ -101 dBm for a (S+N)/N ratio of 6 dB
	≤ -93 dBm for a (S+N)/N ratio of 6 dB (qualified under environmental conditions)
Effective bandwidth (8.33 kHz channel spacing)	≥ ±2.78 kHz at the 6 dB points
	≤ ±7.37 kHz at the 60 dB points
Effective bandwidth (25 kHz channel spacing)	≥ ±8 kHz at the 6 dB points
	≤ ±22 kHz at the 60 dB points
Squelch	level adjustable
AGC characteristic	≤ 6 dB in range -93...0 dBm
Distortion	≤ 15% at 70% of rated output power
Audio frequency response (8.33 kHz channel spacing)	≤ 6 dB 350...2500 Hz
	≥ 35 dB at 4000 Hz

Technical Data

Receiver Data AR62XX, RT62X1	
Audio Noise	≤ 6 dB 300...3400 Hz
	≥ 18 dB at 4000 Hz
Rated output power for speaker operation	≥ 4 W into 4 Ω
Rated output power for headphone 1	≥ 300 mW into 75 Ω
	≥ 100 mW into 600 Ω
Rated output power for headphone 2	≥ 200 mW into 75 Ω
	≥ 100 mW into 600 Ω
Audio auxiliary input	50 mV...8 V (adjustable) across 600 Ω
Offset-carrier operation	YES (25/8.33 kHz)

1.8.4 Transmitter Data AR62XX, RT62X1

Transmitter Data AR62XX, RT62X1	
Output power into 50 Ω (with and without modulation)	≥ 6 W for AR62XX-(X2X) and RT62X1-(X2X)
	≥ 10 W for AR62XX-(X1X) and RT62X1-(X1X)
Frequency tolerance	$\leq \pm 5$ ppm
Duty cycle	120 s (TX): 480 s (RX)
Type of modulation	A3E
Modulation capability	$\geq 70\%$
Distortion	$\leq 15\%$
Audio frequency response (8.33 kHz channel spacing)	≤ 6 dB, 350...2500 Hz
Audio frequency response (25 kHz channel spacing)	≤ 6 dB, 300...2500 Hz
Dynamic microphone	0.5...25 mV compressor starting point, adjustable
(with compressor)	Input balanced, 200 Ω Input range up to 20 dB above compressor starting point.
Standard microphone(s)	9...1500 mV compressor starting point, adjustable
(with compressor)	Input unbalanced, 150 Ω Input range up to 20 dB above compressor starting point.
FM deviation with modulation	≤ 3 kHz
Sidetone	adjustable
PTT stuck detection of transmit mode	120 s
	(Factory configurable 30...120 s)

1.8.5 Emergency Operation

Emergency Operation: 9.0...10.25 VDC (decreased performance).

SAFETY INSTRUCTIONS

- The display shows "LOW BATT" if the supply voltage is less than the predefined threshold.
 - That is the notice for the user, that he should connect a headset because the speaker could be turned off soon.
- If the supply voltage is < 10.25 V, the device continues operation with decreased performance.
 - The speaker output of the transceiver is automatically set to "OFF" without further indication.
 - A headset is required to continue operation of the transceiver.
- If the supply voltage is < 9.0 Volt, the device is automatically set to "OFF".

AR62XX, RCU62X1 (Emergency Operation)	Specifications
Panel & Display Backlight	turned off
TX Output Power	≥ 2 W into 50 Ω (with modulation)
TX Modulation Depth	≥ 50%
RX Sensitivity	≤ -93 dBm for a (S+N)/N ratio of 6 dB

1.8.6 Dimensions & Weight

	AR62X1	AR62X3	RCU62X1	RT62X1
Front panel (W x H)	61 x 61 mm (2.4 x 2.4 inch)	158.8 x 41.2 mm (6.25 x 1.62 inch)	61 x 61 mm (2.4 x 2.4 inch)	61 x 61 mm (2.4 x 2.4 inch)
Device depth	205.7 mm (8.98 inch)	224.4 mm (8.83 inch)	65.9 mm (2.59 inch)	188 mm (7.4 inch)
Mounting depth	184.8 mm (7.28 inch)	224.4 mm (8.83 inch)	39.3 mm (1.55 inch)	188 mm (7.4 inch)
Installation method	Rear panel Ø58 mm (2¼ inch)	Mounting kit MK6403-1 panel mount 160 mm (6.3 inch)	Rear panel Ø58 mm (2¼ inch)	Mounting kit* MK6201-(010)
Material	AlMg/Plastic	AlMg/Plastic	AlMg/Plastic	AlMg
Surface treatment	Control-head coated with black matt paint			N/A
Weight	675 g (1.488 lbs)	800 g (1.763 lbs)	200 g (0.44 lbs)	600 g (1.32 lbs)

Notice: *Use the installation method with the mounting kit to obey the conditions for certification.

1.8.7 Software

1.8.7.1 AR620X Family Software

The design and development processes used for AR620X family software are compliant with the rules given in EUROCAE/RTCA Document ED-12B/DO-178B; "Software Considerations in Airborne System and Equipment Certification". Hereby 'Design Assurance Level' (DAL) "C" was followed. The complete software documentation is based on this level.

Nevertheless, Becker claimed for AR6201 family software in accordance with EUROCAE/RTCA Document ED-12B/DO-178B the:

Design Assurance Level D

Refer to AC 23.1309-1D and/or AC 23.1309-1E to see limitations for installations into aircraft.

The conditions and tests required for TSO approval of this article are minimum performance standards. It is the responsibility of those installing this article either on or in a specific type or class of aircraft to determine that the aircraft installation conditions are in the TSO standards. TSO articles must have separate approval for installation in an aircraft. The article may be installed only in compliance with 14 CFR part 43 or the applicable airworthiness requirements.

1.8.7.2 AR621X Family Software

The design and development processes used for AR621X family software are compliant with the rules given in EUROCAE/RTCA Document ED-12B/DO-178B; "Software Considerations in Airborne System and Equipment Certification". Hereby 'Design Assurance Level' (DAL) "C" was followed.

The complete software documentation is based on this level:

Design Assurance Level C

1.8.8 Hardware

The devices do not contain Complex Electronic Hardware (CEH).

1.8.9 Continued Airworthiness

A regular maintenance of the devices is not necessary:

- The maintenance is specified as "on condition" only.
- It is recommended to make a test of the frequency accuracy of the airborne transceiver after 7 years.

1.8.10 Environmental Conditions AR62X1-(X1X), RT62X1-(X1X)

The test was done in accordance with EUROCAE/RTCA Document ED-14F/DO-160E under consideration of the recorded environmental categories and conditions:

Environmental Conditions	Section	Cat.	Remarks
Temperature and Altitude	4	C4	
Ground Survival Low Temperature	4.5.1		-55 °C
Short-Time Operating Low Temperature	4.5.1		-20 °C -40 °C for RT62X1
Operating Low Temperature	4.5.2		-20 °C -40 °C for RT62X1
Ground Survival High Temperature	4.5.3		+85 °C
Short-Time Operating High Temperature	4.5.3		+70 °C
Operating High Temperature	4.5.4		+55 °C
In-flight Loss of Cooling	4.5.5	X	No forced cooling required
Altitude	4.6.1	C4	35 000 ft
Decompression	4.6.2		No test done
Overpressure	4.6.3		No test done
Temperature Variation	5	B	5 °C per minute
Humidity	6	A	Standard
Shock and Crash Safety	7	B	-
Operational Shocks	7.2		6 g
Crash Safety	7.3		Fixed-wing and helicopter, standard
Vibration	8	S U	Curve M for fixed-wing aircraft Curve G for helicopters
Explosion Atmosphere	9	X	No test done
Waterproofness	10	Y	Condensation
Fluids Susceptibility	11	X	No test done
Sand and Dust	12	X	No test done
Fungus Resistance	13	X	No test done
Salt Fog	14	X	No test done
Magnetic Effect	15	Z	< 1° deflection at 0.3 m
Power Input	16	B	-
Voltage Spike	17	A	-
Audio Freq. Conducted Susceptibility	18	B	-
Induced Signal Susceptibility	19	AC	Primary power DC

Technical Data

Environmental Conditions	Section	Cat.	Remarks
Radio Frequency Susceptibility	20	SW	-
Emission of Radio Frequency Energy	21	B	-
Lightning Induced Transients Susceptibility	22	A1E3X	-
Lightning Direct Effects	23	X	No test done
Icing	24	X	No test done
Electrostatic Discharge (ESD)	25	A	-
Fire, Flammability	26	X	No test done

1.8.11 Environmental Conditions AR62X1-(X2X), RT62X1-(X2X)

The test was done in accordance with EUROCAE/RTCA Document ED-14F/DO-160F under consideration of the recorded environmental categories and conditions:

Environmental Conditions	Section	Cat.	Remarks
Temperature and Altitude	4		
Ground Survival Low Temperature	4.5.1		-55 °C
Short-Time Operating Low Temperature	4.5.1		-20 °C -40 °C for RT62X1
Operating Low Temperature	4.5.2	C4	-20 °C -40 °C for RT62X1
Ground Survival High Temperature	4.5.3		+85 °C
Short-Time Operating High Temperature	4.5.3		+70 °C
Operating High Temperature	4.5.4		+55 °C
In-flight Loss of Cooling	4.5.5	X	No forced cooling required
Altitude	4.6.1		35 000 ft
Decompression	4.6.2	C4	No test done
Overpressure	4.6.3		No test done
Temperature Variation	5	B	5 °C per minute
Humidity	6	A	Standard
Shock and Crash Safety	7		-
Operational Shocks	7.2	B	6 g
Crash Safety	7.3		Fixed-wing and helicopter, standard
Vibration	8	S U	Curve M for fixed-wing aircraft Curve G for helicopters
Explosion Atmosphere	9	X	No test done
Waterproofness	10	Y	Condensation

Environmental Conditions	Section	Cat.	Remarks
Fluids Susceptibility	11	X	No test done
Sand and Dust	12	X	No test done
Fungus Resistance	13	X	No test done
Salt Fog	14	X	No test done
Magnetic Effect	15	Z	< 1° deflection at 0.3 m
Power Input	16	B	-
Voltage Spike	17	A	-
Audio Freq. Conducted Susceptibility	18	B	-
Induced Signal Susceptibility	19	AC	Primary power DC
Radio Frequency Susceptibility	20	RW	-
Emission of Radio Frequency Energy	21	B	-
Lightning Induced Transients Susceptibility	22	A1E3X	-
Lightning Direct Effects	23	X	No test done
Icing	24	X	No test done
Electrostatic Discharge (ESD)	25	A	-
Fire, Flammability	26	X	No test done

1.8.12 Environmental Conditions AR62X3-()

The test was done in accordance with EUROCAE/RTCA Document ED-14F/DO-160F under consideration of the recorded environmental categories and conditions:

Environmental Conditions	Section	Cat.	Remarks
Temperature and Altitude	4	C4	
Ground Survival Low Temperature	4.5.1		-55 °C
Short-Time Operating Low Temperature	4.5.1		-20 °C -40 °C for RT62X1
Operating Low Temperature	4.5.2		-20 °C -40 °C for RT62X1
Ground Survival High Temperature	4.5.3		+85 °C
Short-Time Operating High Temperature	4.5.3		+70 °C
Operating High Temperature	4.5.4		+55 °C
In-flight Loss of Cooling	4.5.5	X	No forced cooling required
Altitude	4.6.1	C4	35 000 ft
Decompression	4.6.2		No test done
Overpressure	4.6.3		No test done
Temperature Variation	5	B	5 °C per minute
Humidity	6	A	Standard

Technical Data

Environmental Conditions	Section	Cat.	Remarks
Shock and Crash Safety	7	B	-
Operational Shocks	7.2		6 g
Crash Safety	7.3		Fixed-wing and helicopter, standard
Vibration	8	SM U2	Curve M for fixed-wing aircraft Curve G for helicopters
Explosion Atmosphere	9	X	No test done
Waterproofness	10	Y	Condensation
Fluids Susceptibility	11	X	No test done
Sand and Dust	12	X	No test done
Fungus Resistance	13	X	No test done
Salt Fog	14	X	No test done
Magnetic Effect	15	Z	< 1° deflection at 0.3 m
Power Input	16	BIX	-
Voltage Spike	17	A	-
Audio Freq. Conducted Susceptibility	18	B	-
Induced Signal Susceptibility	19	AC	Primary power DC
Radio Frequency Susceptibility	20	SW	-
Emission of Radio Frequency Energy	21	B	-
Lightning Induced Transients Susceptibility	22	A1E3X	-
Lightning Direct Effects	23	X	No test done
Icing	24	X	No test done
Electrostatic Discharge (ESD)	25	A	-
Fire, Flammability	26	X	No test done

1.8.13 Environmental Conditions RCU62X1-()

The test was done in accordance with EUROCAE/RTCA Document ED-14F/DO-160F under consideration of the recorded environmental categories and conditions:

Environmental Conditions	Section	Cat.	Remarks
Temperature and Altitude	4		
Ground Survival Low Temperature	4.5.1	C4	-55 °C
Short-Time Operating Low Temperature	4.5.1		-20 °C
Operating Low Temperature	4.5.2		-20 °C
Ground Survival High Temperature	4.5.3		+85 °C
Short-Time Operating High Temperature	4.5.3		+70 °C
Operating High Temperature	4.5.4		+55 °C
In-flight Loss of Cooling	4.5.5		X
Altitude	4.6.1	C4	35 000 ft
Decompression	4.6.2		No test done
Overpressure	4.6.3		No test done
Temperature Variation	5	B	5 °C per minute
Humidity	6	A	Standard
Shock and Crash Safety	7	B	-
Operational Shocks	7.2		6 g
Crash Safety	7.3		Fixed-wing and helicopter, standard
Vibration	8	S U	Curve M for fixed-wing aircraft Curve G for helicopters
Explosion Atmosphere	9	X	No test done
Waterproofness	10	X	No test done
Fluids Susceptibility	11	X	No test done
Sand and Dust	12	X	No test done
Fungus Resistance	13	X	No test done
Salt Fog	14	X	No test done
Magnetic Effect	15	Z	< 1° deflection at 0.3 m
Power Input	16	B	-
Voltage Spike	17	B	-
Audio Freq. Conducted Susceptibility	18	B	-
Induced Signal Susceptibility	19	W	Primary power DC
Radio Frequency Susceptibility	20	W	-
Emission of Radio Frequency Energy	21	B	-
Lightning Induced Transients Susceptibility	22	A1E3X	-
Lightning Direct Effects	23	X	No test done
Icing	24	X	No test done
Electrostatic Discharge (ESD)	25	A	-
Fire, Flammability	26	X	No test done

1.8.14 Certifications

**SAFETY
INSTRUCTIONS**

Unauthorized changes or modifications to the device(s) may void the compliance to the required regulatory agencies and authorization for continued equipment usage.

1.8.14.1 AR6201, AR6211 Single Block Transceiver

Part Number	Article Number	EASA Approval	TSO Conformity	FCC Approval
AR6201-(012)	0631.418-910	EASA.210.1249 ETSO-2C37e Class: D, E ETSO-2C38e Class: 4, 6	TSO-C169a Class: D, E, 4, 6	B54AR6201
AR6201-(112)	0631.434-910	EASA.210.1249 ETSO-2C37e Class: D ETSO-2C38e Class: 4	TSO-C169a Class: D, 4	B54AR6201
AR6201-(022)	0636.339-910	EASA.210.1249 ETSO-2C37e ETSO-2C38e Class: D, E, 4, 6	TSO-C169a Class: D, E, 4, 6	B54AR6201
AR6201-(122)	0636.355-910	EASA.210.1249 ETSO-2C37e Class: D ETSO-2C38e Class: 4, Class: D, 4	TSO-C169a Class: D, 4	B54AR6201
AR6211-(012)	0662.410-910	EASA.210.10075461 ETSO-2C169a Class: C, H2, 4, 6	TSO-2C169a	B54AR6201
AR6211-(112)	0662.437-910	EASA.210.10075461 ETSO-2C169a Class: C, 4	TSO-2C169a	B54AR6201
AR6211-(022)	0662.429-910	EASA.210.10075461 ETSO-2C169a Class: C, H2, 4, 6	TSO-2C169a	B54AR6201
AR6211-(122)	0662.445-910	EASA.210.10075461 ETSO-2C169a Class: C, 4	TSO-2C169a	B54AR6201

1.8.14.2 RT6201, RT6211 Remote-Controlled Transceiver

Part Number	Article Number	EASA Approval	TSO Conformity	FCC Approval
RT6201-(010)	0631.442-910	EASA.210.1249 ETSO-2C37e Class: D, E ETSO-2C38e Class: 4, 6	TSO-C169a Class: D, E, 4, 6	B54AR6201
RT6201-(020)	0636.312-910			
RT6211-(010)	0662.471-910	EASA.210.10075461 ETSO-2C169a Class: C, H2, 4, 6	TSO-2C169a	B54AR6201
RT6211-(020)	0662.488-910	EASA.210.10075461 ETSO-2C169a Class: C, H2, 4, 6		

1.8.14.3 RCU6201, RCU6211 Remote Control Unit

Part Number	Article Number	EASA Approval	TSO Conformity	FCC Approval
RCU6201-(012)	0631.469-910	EASA.210.1249 ETSO-2C37e Class: D, E ETSO-2C38e Class: 4, 6	TSO-C169a Class: D, E, 4, 6	B54AR6201
RCU6201-(112)	0631.485-910	EASA.210.1249 ETSO-2C37e Class: D ETSO-2C38e Class: 4	TSO-C169a Class: D, 4	B54AR6201
RCU6211-(012)	0662.453-910	EASA.210.10075461 ETSO-2C169a Class: C, H2, 4, 6	TSO-2C169a	B54AR6201
RCU6211-(112)	0662.461-910	EASA.210.10075461 ETSO-2C169a Class: C, 4	TSO-2C169a	B54AR6201

Technical Data

1.8.14.4 AR6203, AR6213 Single Block Transceiver

Part Number	Article Number	EASA Approval	TSO Conformity	FCC Approval
AR6203-(012)	0630.993-910	EASA.210.10054849 ETSO-2C169a Class: C, H2, 4, 6	TSO-C169a Class: D, E, 4, 6	B54AR6203
AR6203-(112)	0631.566-910	EASA.210.10054849 ETSO-2C169a Class: C, 4	TSO-C169a Class: C, 4	B54AR6203
AR6203-(022)	0636.371-910	EASA.210.10054849 ETSO-2C169a Class: C, H2, 4, 6	TSO-C169a Class: D, E, 4, 6	B54AR6203
AR6203-(122)	0636.398-910	EASA.210.10054849 ETSO-2C169a Class: C, 4	TSO-C169a Class: C, 4	B54AR6203
AR6213-(012)	0662.518-910	EASA.210.10075461 ETSO-2C169a Class: C, H2, 4, 6	TSO-2C169a	B54AR6203
AR6213-(112)	0662.534-910	EASA.210.10075461 ETSO-2C169a Class: C, 4	TSO-2C169a	B54AR6203
AR6213-(022)	0662.526-910	EASA.210.10075461 ETSO-2C169a Class: C, H2, 4, 6	TSO-2C169a	B54AR6203
AR6213-(122)	0662.542-910	EASA.210.10075461 ETSO-2C169a Class: C, 4	TSO-2C169a	B54AR6203

1.8.14.5 FCC Approval

Radiofrequency radiation exposure information:

The approved equipment complies with FCC radiation exposure limits set forth for an uncontrolled environment. The equipment should be installed and operated with minimum distance of 50 cm between the radiator and your body.

This transmitter must not be co-located or operated in conjunction with any other antenna or transmitter.

NOTICE:

The approved equipment has been tested and found to comply with the limits for a 'Licensed Non-Broadcast Station Transmitter' (VHF-Transceiver),, pursuant to Part 87 of the FCC Rules. It is designed to provide reasonable protection against harmful interference when the equipment is operated in a commercial environment. This equipment generates, uses, and can radiate radio frequency energy and, if not installed and used in accordance with the instruction manual, may cause harmful interference to radio communications. Operation of this equipment in a residential area is likely to cause harmful interference in which case the user will be required to correct the interference at his own expense.

NOTICE:

This device complies with Part 87 of the FCC Rules [and with Industry Canada license-exempt RSS standard(s)].

Operation is subject to the two conditions that follow:

- This device may not cause harmful interference, and
- This device must accept any interference received, including interference that may cause undesired operation.

NOTICE:

Changes or modifications made to the approved equipment not expressly approved by Becker Avionics may void the FCC authorization to operate this equipment.

Order Code

1.9 Order Code**1.9.1 Devices 62XX Series**

Qty	AR62X1 Single Block Transceiver	
1	AR6201-(012), 8.33/25 kHz, 10 W at 28 V	Article-No. 0631.418-910
1	AR6201-(022), 8.33/25 kHz, 6 W at 12 V	Article-No. 0636.339-910
1	AR6201-(112), 25 kHz, 10 W at 28 V	Article-No. 0631.434-910
1	AR6201-(122), 25 kHz, 6 W at 12 V	Article-No. 0636.355-910
1	AR6211-(012), 8.33/25 kHz, 10 W at 28 V	Article-No. 0662.410-910
1	AR6211-(022), 8.33/25 kHz, 6 W at 12 V	Article-No. 0662.437-910
1	AR6211-(112), 25 kHz, 10 W at 28 V	Article-No. 0662.429-910
1	AR6211-(122), 25 kHz, 6 W at 12 V	Article-No. 0662.445-910

Qty	RT62 Remote-Controlled Transceiver	
1	RT6201-(010), 8.33/25 kHz, 10 W at 28 V	Article-No. 0631.442-910
1	RT6201-(020), 8.33/25 kHz, 6 W at 12 V	Article-No. 0636.312-910
1	RT6201-(110), 25 kHz, 10 W at 28 V	Article-No. 0638.609-910
1	RT6201-(120), 25 kHz, 6 W at 12 V	Article-No. 0638.617-910
1	RT6211-(010), 8.33/25 kHz, 10 W at 28 V	Article-No. 0662.471-910
1	RT6211-(020), 8.33/25 kHz, 6 W at 12 V	Article-No. 0662.488-910

Qty	RCU62 Remote Control Unit	
1	RCU6201-(012), 8.33/25 kHz	Article-No. 0631.469-910
1	RCU6201-(112), 25 kHz	Article-No. 0631.485-910
1	RCU6211-(012), 8.33/25 kHz	Article-No. 0662.453-910
1	RCU6211-(112), 25 kHz	Article-No. 0662.461-910

Qty	AR62X3 Single Block Transceiver, 160 mm	
1	AR6203-(012), 8.33/25 kHz, 10 W at 28 V	Article-No. 0630.993-910
1	AR6203-(022), 8.33/25 kHz, 6 W at 12 V	Article-No. 0636.371-910
1	AR6203-(112), 25 kHz, 10 W at 28 V	Article-No. 0631.566-910
1	AR6203-(122), 25 kHz, 6 W at 12 V	Article-No. 0636.398-910
1	AR6213-(012), 8.33/25 kHz, 10 W at 28 V	Article-No. 0662.518-910
1	AR6213-(022), 8.33/25 kHz, 6 W at 12 V	Article-No. 0662.534-910
1	AR6213-(112), 25 kHz, 10 W at 28 V	Article-No. 0662.526-910
1	AR6213-(122), 25 kHz, 6 W at 12 V	Article-No. 0662.542-910

1.9.2 Accessories

Qty	Connector Kit	
1	CK4201-S (soldering version); <ul style="list-style-type: none"> D-Sub 25-s, Connector housing, Antenna plug, Label "COMM" 	Article-No. 0879.304-954
1	CK4201-C (crimp version); <ul style="list-style-type: none"> D-Sub 25-c, Connector housing, Antenna plug, Label "COMM" 	Article-No. 0514.901-954
1	CK6000-S (soldering version); <ul style="list-style-type: none"> D-Sub Connector LE M 25pol, Connector housing 	Article-No. 0640.621-954
1	CK6000-C (crimp version); <ul style="list-style-type: none"> D-Sub Connector LE M 25pol, Connector housing 	Article-No. 0640.611-954
1	CK6200-S (soldering version); <ul style="list-style-type: none"> D-Sub 25-s, D-Sub 25-p,2 Connector housings, Antenna plug, Label "COMM" 	Article-No. 0617.903-954
1	CK6200-C (crimp version); <ul style="list-style-type: none"> D-Sub 25-s, D-Sub 25-p,2 Connector housings, Antenna plug, Label "COMM", Coding key 	Article-No. 0617.891-954
1	CK5000-S (soldering version); <ul style="list-style-type: none"> D-Sub 15-s, Connector housing, Label "COMM", Label "NAV", Label "ADF", Label "XPDR" 	Article-No. 0511.791-954
1	CK5000-C (crimp version); <ul style="list-style-type: none"> D-Sub 15-s, Connector housing, Label "COMM", Label "NAV", Label "ADF", Label "XPDR" 	Article-No. 0511.781-954

Qty	Cable Harness	
1	1K062 Cable harness AR62XX (open cable ends), length 3.7 m, for sailplanes, motor gliders, to be used for: <ul style="list-style-type: none"> Headphone Dynamic microphone Speaker PTT switch Power supply 	Article-No. 0621.390-950
1	1K065 Cable harness AR62XX (prepared with connectors), length 3.7 m, for general aviation, to be used for: <ul style="list-style-type: none"> 2x Phone, jack socket PJ55 2x Standard microphone, jack socket PJ68 1x PTT switch 1x Audio in, jack socket 3.5 mm 1x Power supply 	Article-No. 0621.455-950

For details please refer to "Cable Harness", page 111.

Qty	Installation Material	
1	Mounting Kit MK6201-(010)	Article-No. 0631.515-261
1	Mounting Kit MK6403-1 <ul style="list-style-type: none"> 6x Attachment screws 6x Attachment clips 	Article-No. 0598.569-284
1	Adapter for AR3201 wiring 1AD042	Article-No. 0877.522-959

Order Code

1.9.3 Spare Parts

Qty	Installation Material	
1	PHILLIPS head screw black (for rear panel installation)	Article-No. 0868.590-203

1.9.4 Documentation

Qty	Documentation	
1	(OI) Operating Instructions, English AR62XX, RT62X1, RCU62X1	Article-No. 0638.420-071
1	(BA) Bedienungsanleitung, German AR62XX, RT62X1, RCU62X1	Article-No. 0641.413-071
1	(I&O) Installation and Operation manual, English VHF-Transceivers 6200 Series (AR62XX, RT62X1, RCU62X1 from SW SCI1050S305 Version 4.06, SCI1051S305 Version 2.06),	Article-No. 0638.404-071
1	(M&R) Maintenance and Repair manual, English VHF-Transceivers 6200 Series (AR62XX, RT62X1, RCU62X1 from SW SCI1050S305 Version 4.06, SCI1051S305 Version 2.06	Article-No. 0638.412-071
1	(E&B) Einbau und Bedienung, German AR620X, RT6201, RCU6201 from SW SCI1050S305 Version 4.06, SCI1051S305 Version 2.06	Article-No. 0648.078-071
1	(I&F) Installation et fonctionnement, French AR620X, RT6201, RCU6201 from SW SCI1050S305 Version 4.06, SCI1051S305 Version 2.06)	Article-No. 0647.705-071
1	AR6201 Retrofit-Instructions, English	Article-No. 0649.996-071

2 Installation

This manual must be available to the installer during performance of all tasks.

The installation of the device(s) depends on the type of aircraft and its equipment and therefore only general information can be given in this section.

Any deviations from the installation instructions in this document are under own responsibility.

In this chapter you can read about:

2.1	Packaging, Transport, Storage	44
2.2	Device Assignment	45
2.2.1	Scope of Delivery	45
2.2.2	State of Delivery	45
2.2.3	Additional Required Equipment	45
2.2.4	Registration of the Device	45
2.2.5	Type Plate	46
2.2.6	Software/Firmware Status – Functionality	46
2.3	Installation Requirements	47
2.3.1	Installation in the Avionic Compartment	48
2.3.2	Cockpit Panel Installation	49
2.3.3	Rear Panel Installation	49
2.4	Dimensions	50
2.4.1	AR6201, AR6211	50
2.4.2	AR6203, AR6213	51
2.4.3	RCU62X1	52
2.4.4	RT62X1	53
2.4.5	RT62X1 with MK6201	54
2.4.6	Mounting kit - MK6201	55
2.4.7	Mounting kit - MK6403-1	56
2.5	Connector Pin Assignments	57
2.5.1	Device Connectors (AR62XX, RT62X1)	57
2.5.2	Antenna Connector (AR62XX, RT62X1)	57
2.5.3	Grounding Bolt (AR62XX, RT62X1)	57
2.5.4	Inputs / Outputs (AR62XX, RT62X1)	60
2.5.5	Device Connector (RCU62X1)	64
2.5.6	Inputs / Outputs (RCU62X1)	65
2.6	Installation and Configuration	66
2.6.1	General Requirements	66
2.6.2	Customized Applications	66
2.6.3	Antenna Installation	66
2.7	Configuration Setup	69
2.7.1	Configuration Interface	69
2.7.2	Start Configuration Setup	69
2.7.3	Volume Adjustment (VU Meter)	70
2.7.4	Device Info	71
2.7.5	Dimming, Brightness	72
2.7.6	Illumination Curve	73
2.7.7	Memory Options	74
2.7.8	Modification, Battery	74
2.7.9	Configuration	75
2.7.10	Auxiliary Audio Input	76
2.7.11	IN/OUT CFG1	76
2.7.12	IN/OUT CFG2	78
2.7.13	Standard Microphone 1	79
2.7.14	Standard Microphone 2	80
2.7.15	Standard Microphone 3	81
2.7.16	Dynamic Microphone	82
2.7.17	Speaker	82
2.7.18	Squelch	83
2.7.19	Scan Hold Time	83
2.7.20	Sidetone	83
2.7.21	Erase Memory	84
2.7.22	Fail List	85
2.7.23	Recall Default Settings	85

Packaging, Transport, Storage

2.8	Factory Default Settings	86
2.9	Aircraft Wiring	88
2.9.1	Electrical Bonding and Grounding	88
2.9.2	Single Seat Glider	88
2.9.3	Installation with RT62X1 and RCU62X1	91
2.9.4	Twin Seat with RT62X1 (Tandem-Installation)	92
2.9.5	Twin Seat Motor Glider	94
2.9.6	General Aviation (GA) Aircraft.....	96
2.9.7	Individual Dual Headset Installation (two IC Circuits).....	98
2.9.8	Twin Seat with AR62XX (Tandem-Installation).....	100
2.9.9	Four Seat Installation (no Tandem)	102
2.9.10	Installation in Aircraft with Intercom System	104
2.9.11	Recommendation for the Installation of two Transceivers in one Aircraft.....	107
2.9.12	Cable Harness	111
2.10	Retrofitting - AR4201 with AR62X1	113
2.10.1	Wiring AR4201 - AR62X1	113
2.10.2	Dynamic Microphone Input	114
2.10.3	Temperature Sensor	115
2.10.4	RS232 Interface	115
2.10.5	AFCU/AGC/AFWB	115
2.10.6	CPIN (if Installed).....	115
2.10.7	+13.75 V (AR4201) - PWR_EVAL (AR62X1)	115
2.11	Post Installation Check.....	116
2.11.1	Mechanical Installation and Wiring Check	116
2.11.2	Power Supply	116
2.11.3	Receiver / Transmitter Operation.....	116
2.11.4	Antenna Check.....	116
2.11.5	Interference Check.....	117
2.11.6	Flight Test Check	118
2.12	Error / Failure Indication	118
2.13	Troubleshooting.....	119

2.1 Packaging, Transport, Storage

Visually inspect the package contents for signs of transport damage.

Packaging Material and Transport

⚠CAUTION The packaging material is inflammable, by burning, toxic fumes may develop.

Keep the packaging material and use it in the case of a return shipment. Improper or faulty packaging may lead to transport damages.

Make sure to transport the device always in a safe manner and with the aid of suitable lifting equipment if necessary. Do never use the electric connections for lifting. Before the transport, a clean, level surface should be prepared to put the device on. The electric connections may not be damaged when placing the device.

First Device Checkup

- Do a check for signs of transport damages.
- Please make sure that the indications on the type plate agree with your purchase order.
- Make sure that the equipment is complete ("Scope of Delivery", page 45).

Storage

If you do not install the device immediately, make sure to store it in a dry and clean environment. Make sure that the device is not stored near strong heat sources and that no metal chippings can get into the device.

2.2 Device Assignment

This manual is for devices upwards from software version:

SCI1050S305 Version 4.06

SCI1051S305 Version 2.06

Single block devices:	Remote-control devices:
<ul style="list-style-type: none"> • AR6201-(012) • AR6201-(022) • AR6201-(112) • AR6201-(122) • AR6211-(012) • AR6211-(022) • AR6211-(112) • AR6211-(122) 	<ul style="list-style-type: none"> • RT6201-(010) • RT6201-(020) • RT6201-(110) • RT6201-(120) • RT6211-(010) • RT6211-(020)
<ul style="list-style-type: none"> • AR6203-(012) • AR6203-(022) • AR6203-(112) • AR6203-(122) • AR6213-(012) • AR6213-(022) • AR6213-(112) • AR6213-(122) 	<ul style="list-style-type: none"> • RCU6201-(012) • RCU6201-(112) • RCU6211-(012) • RCU6211-(112)

2.2.1 Scope of Delivery

- Manuals:
 - Operating Instructions.
- The device(s) as ordered.
- Documents of Certifications Authorized Release Certificate (EASA Form 1).

2.2.2 State of Delivery

- The device(s) are ready for use with factory default adjustments.

2.2.3 Additional Required Equipment

- Mounting kit MK6403-1 (for AR62X3)
- Mounting kit MK6201-(10) (for RT62X1 to obey the conditions for certification).
- Connector kits.
- Cable harness.
- Antenna.
- Microphone.
- Headphone, speaker.

"Accessories", page 41.

2.2.4 Registration of the Device

Obey the national requirements for operation of radio equipment.

2.2.5 Type Plate

The device type is specified by the type plate (on the housing):

Example:



Figure 6: Type Plate (example)

Explanation:

PN:	<p>Type designation: AR6201, AR6211 = Single Block VHF Transceiver 58 mm (2¼ inch) AR6203, AR6213 = Single Block VHF Transceiver 160 mm (3.6 inch) RT6201, RT6211 = Remote-Controlled VHF Transceiver RCU6201, RCU6211 = Remote Control Unit 58 mm (2¼ inch)</p> <p>Options: 0XX: 8.33/25 kHz channel spacing 1XX: 25 kHz channel spacing only X1X: 6 W @ 12 V, 10 W @ 28 V X2X: 6 W @ 12 V XX2: white illumination color on black panel</p>
SN:	Unique number of the device
AN:	Article number
DoM:	Date of Manufacturing
	<p>Software: Refer to the version on the device type plate</p>
	<p>Compliance and Certifications: Refer to the text and logos on the device type plate</p>

2.2.6 Software/Firmware Status – Functionality

- The software version is shown at the screen for a few seconds after power on. This information is also available with the configuration setup → DEVICE INFO.
- The software versions are subject to change without notice.

2.3 Installation Requirements

The installation of the device(s) depends on the type of aircraft and its equipment and therefore only general information can be given in this section.

SAFETY INSTRUCTIONS

The installation of the device(s) into an aircraft may be carried out by an authorized installation company. The country regulations always have to be obeyed.

- The device must not be opened.
- Keep an efficient distance of the devices with integrated ventilator fans in order to make sure the free circulation of the cooling air.
- The installation area must have a minimum distance of 30 cm from the magnetic aircraft compass, to prevent any interference to the magnetic compass (no limit for RCU62X1).
- Forced cooling is not required.

SAFETY INSTRUCTIONS

The device(s) are for installations in general aviation aircraft and helicopters.

- The installation must be in accordance with the local aviation authority approved guidelines (e.g. EASA, FAA).
- The installation must be in accordance with the ETSO/TSO standards applicable for the specified type or class of aircraft.
- The conditions and tests for ETSO/TSO approval of this article are minimum performance standards.
- The 62XX transceiver must be connected to a VHF antenna in order to satisfy FAA TSO-C169a.
- The device(s) are not qualified for installation in areas with fluid contamination.
- Changes or modifications made to this equipment not expressly approved in written form by Becker may void the authorization to operate this equipment.

SAFETY INSTRUCTIONS

- Use only cables which are qualified for aircraft use (self-extinguishing).
- Use AWG 20 for power supply and speaker and AWG 22/24 for other cables.
- Interface lines TX-A/TX-B and RX-A/RX-B are each to be laid as 2-core twisted and shielded cables.
- Fit sleeves over the solder joints on the equipment connector.
- HF cable should not be included in the cable harnesses.
- Use the recommended fuses in the power supply line for the protection of the application, see wiring examples "Aircraft Wiring", page 88.

⚠ CAUTION

- Examine the wiring carefully before power up the device(s) and examine particularly correct connection of the power supply lines.

2.3.1 Installation in the Avionic Compartment

- The RT62X1 is made for installation in avionic compartment.
- Use the mounting kit MK6201-(010) for installation to obey the conditions for certification.
- Attach the mounting tray in the aircraft
 - (see "Dimensions see "Figure 7: RT62X1, MK6201-(10) Installation page 48).
 - Use four M4 (metric) or size 8-32 UNC (imperial) stainless steel screws with countersunk head.
 - A minimum torque for fixing screws is 2.5 Nm (22 inch-lbs).
- Move the flat part "X" of the RT62X1 into the slot S
 - (see "Figure 7: RT62X1, MK6201-(10) Installation page 48).
- Use the screws (A) to tighten the device to the mounting slot
 - (see "Figure 7: RT62X1, MK6201-(10) Installation page 48)
 - Use four M4 (metric) or size 8-32 UNC (imperial) stainless steel screws with countersunk head.
 - A minimum torque for fixing screws is 2.5 Nm (22 inch-lbs).
- More information please see.
 - "Dimensions - RT62X1 with MK6201" page 54,
 - "Dimensions - Mounting kit - MK6201" page 55.

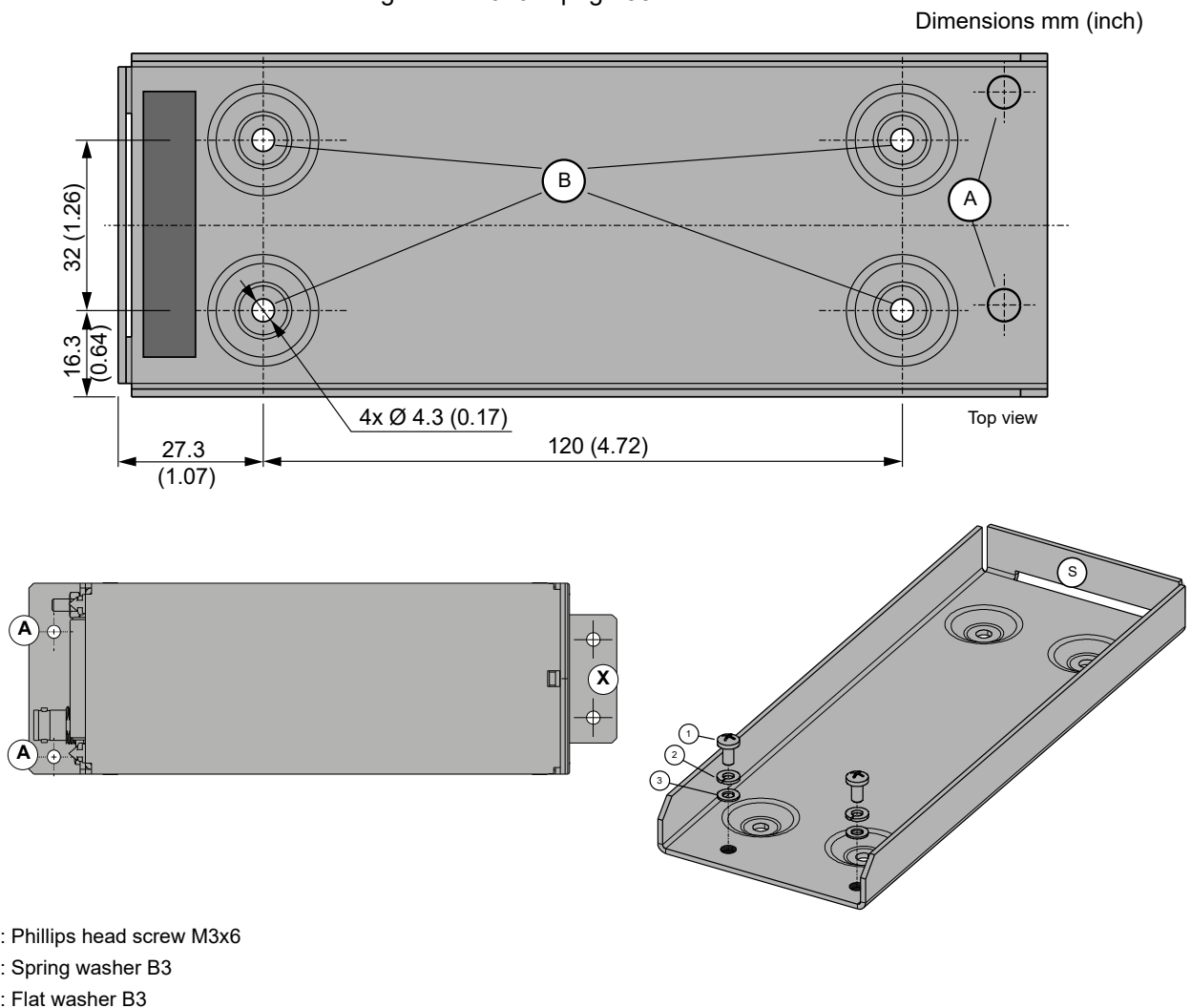

Figure 7: RT62X1, MK6201-(10) Installation

2.3.2 Cockpit Panel Installation

- The AR62X3 is made for cockpit panel installation.
- Use the mounting kit MK6403-1 for installation.
 - Use the holes (2x 3) on both sides of the frame to attach the mounting tray in the aircraft. The screws (6x) and the clips (6x) are included in the delivery.
 - Move the AR62X3 into the mounting tray, use an Allen wrench (3/32") to tighten the device to its final position.
 - A minimum torque for fixing screws is 0.9 Nm (8 inch-lbs).

More information please see "Mounting kit - MK6403-1", page 56.

Dimensions mm (inch)

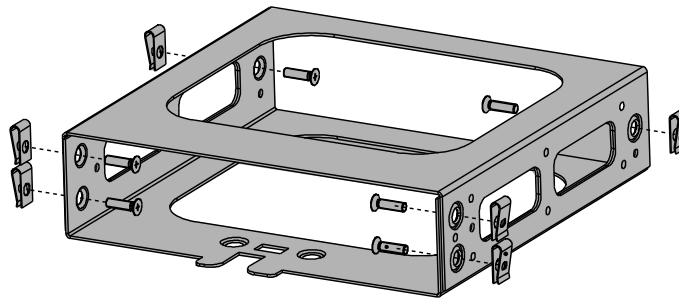

Figure 8: MK6403-1: Cockpit Panel Installation

2.3.3 Rear Panel Installation

- The AR62X1 and RCU62X1 are make for rear panel installation.
 - The four screws for installation are already attached at the front of the device.
 - A minimum torque for fixing screws is 0.9 Nm (8 inch-lbs).
 - More information please see:
 - "Dimensions - AR6201" page 50.
 - "Dimensions -RCU62X1" page 52.

Dimensions mm (inch)



61x61 mm (2.4x2.4 in)

Figure 9: AR62X1, RCU62X1 (front view)

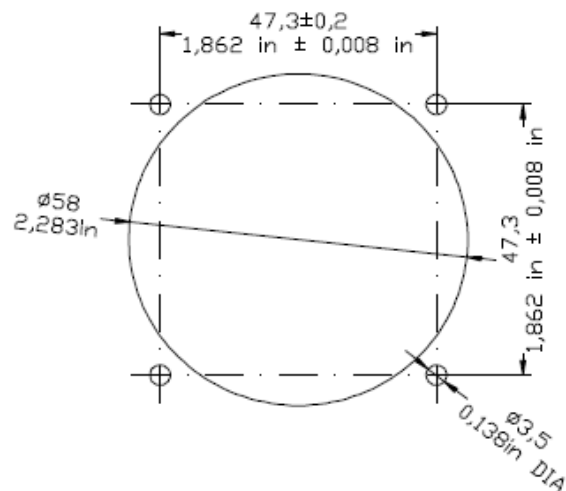

(no scale drawing)

Figure 10: Drilling Template -Rear-Panel Installation

Dimensions

2.4 Dimensions

2.4.1 AR6201, AR6211

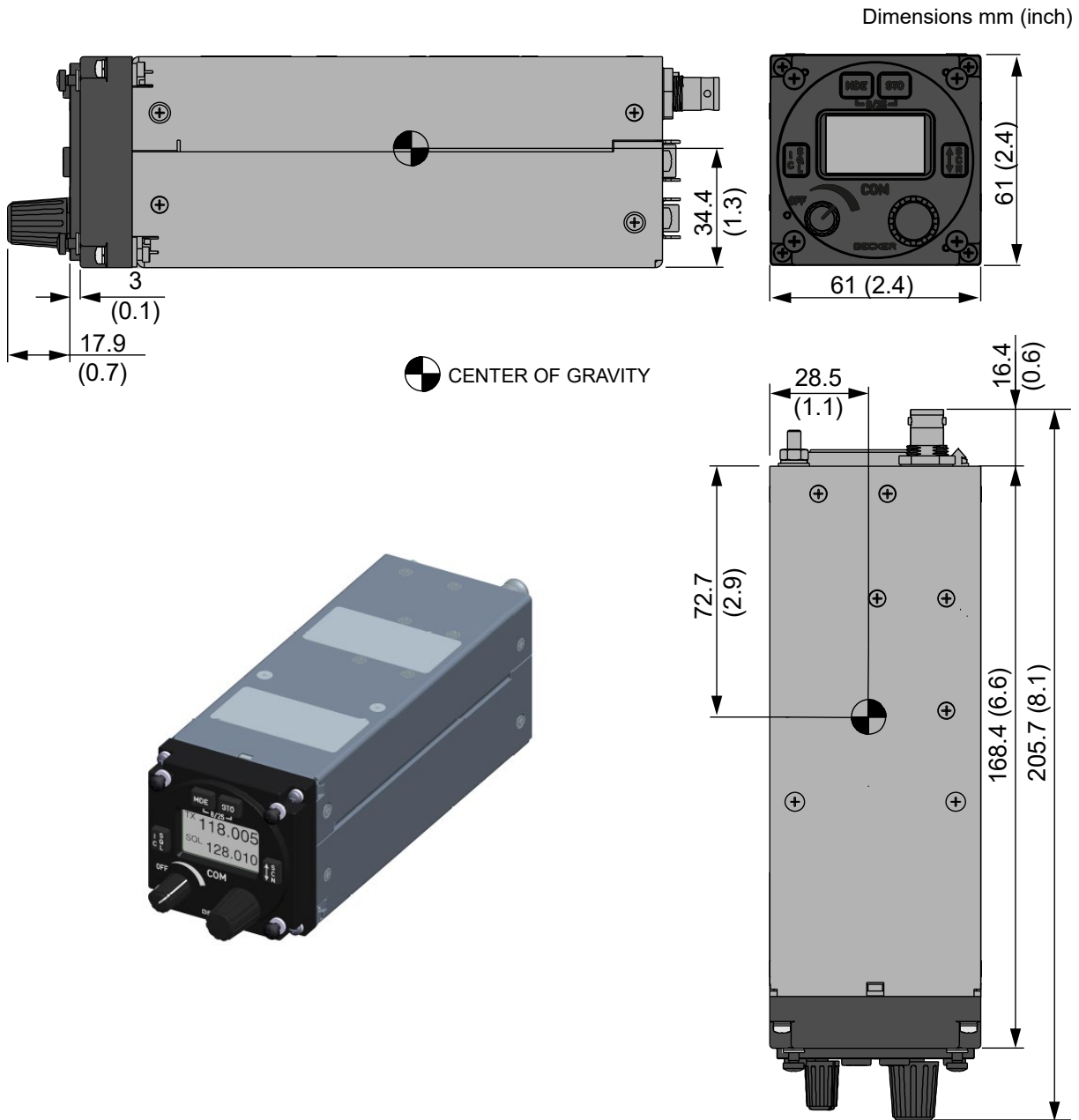

Figure 11: Dimensions - AR6201, AR6211

NOTICE

"Center of Gravity" is without other equipment.

Permitted deviation for dimensions without tolerances: DIN ISO 2768 T1 C (dimensions in mm)		
xx...6 (±0.3)	>30...120 (±0.8)	>400...1000 (±2.0)
>6...30 (±0.5)	>120...400 (±1.2)	>1000...2000 (±3.0)

2.4.2 AR6203, AR6213

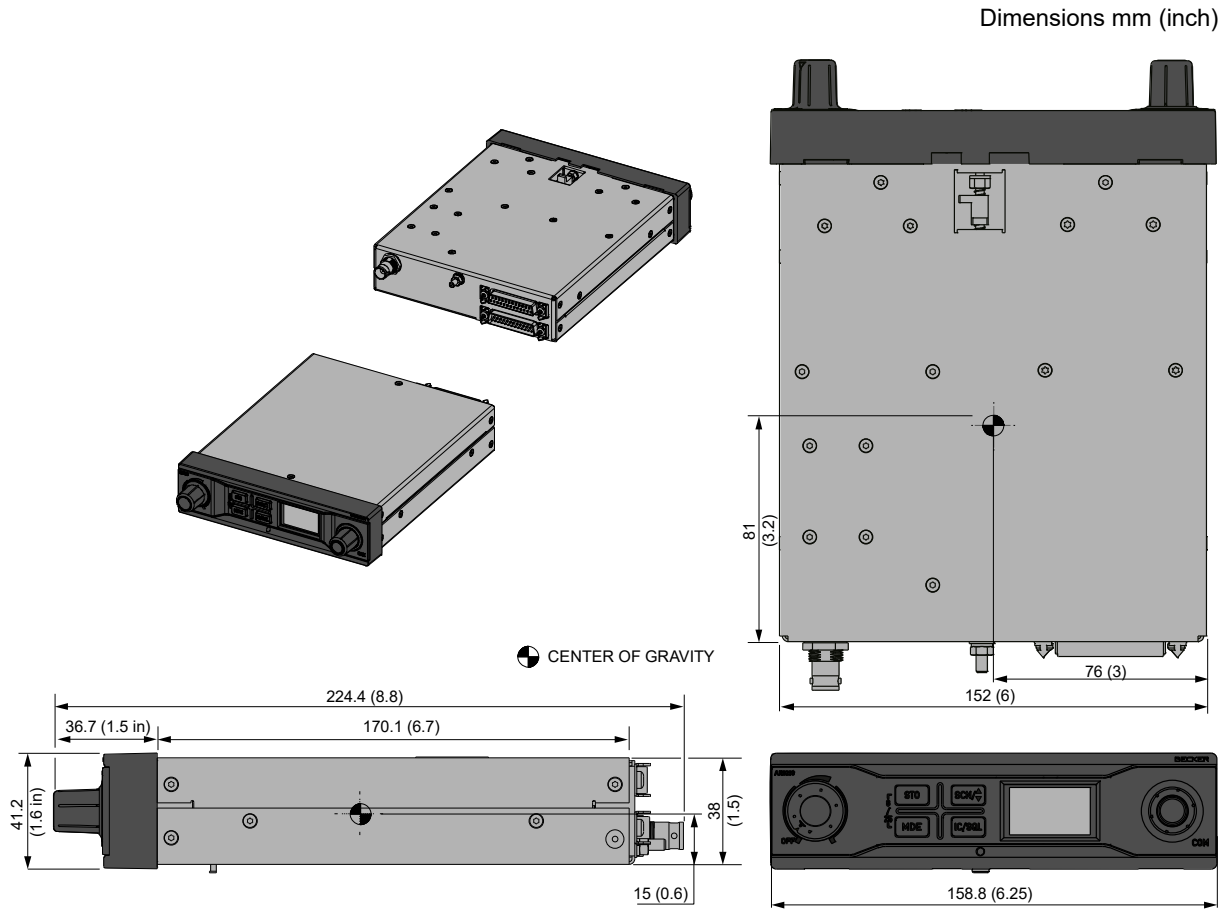

Figure 12: Dimensions - AR6203, AR6213

NOTICE "Center of Gravity" is without other equipment.

Permitted deviation for dimensions without tolerances: DIN ISO 2768 T1 C (dimensions in mm)		
xx...6 (±0.3)	>30...120 (±0.8)	>400...1000 (±2.0)
>6...30 (±0.5)	>120...400 (±1.2)	>1000...2000 (±3.0)

Dimensions

2.4.3 RCU62X1

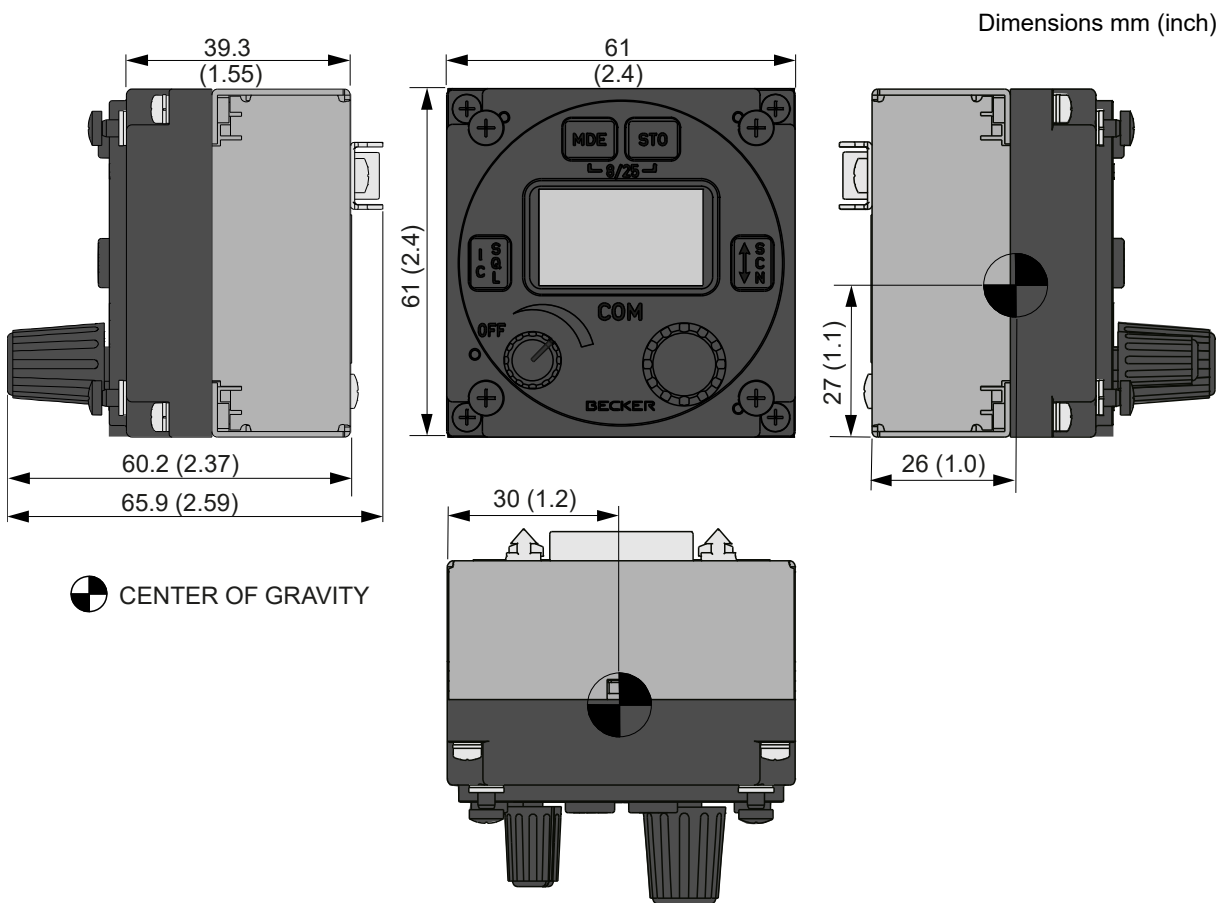

Figure 13: Dimensions - RCU62X1

NOTICE

"Center of Gravity" is without other equipment.

Permitted deviation for dimensions without tolerances: DIN ISO 2768 T1 C (dimensions in mm)		
xx...6 (± 0.3)	>30...120 (± 0.8)	>400...1000 (± 2.0)
>6...30 (± 0.5)	>120...400 (± 1.2)	>1000...2000 (± 3.0)

2.4.4 RT62X1

Dimensions mm (inch)

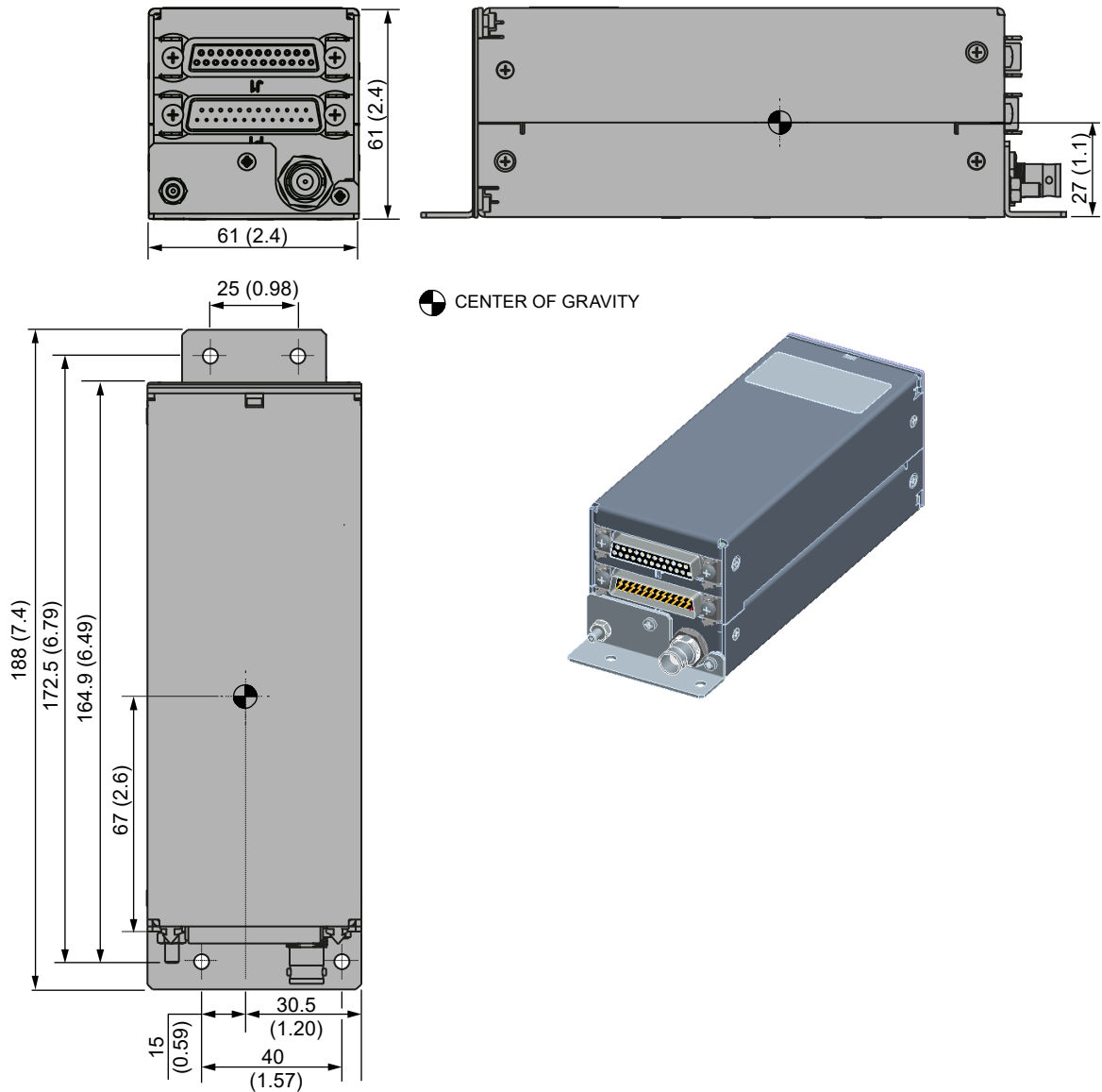

Figure 14: Dimensions - RT62X1

NOTICE "Center of Gravity" is without other equipment.

Permitted deviation for dimensions without tolerances: DIN ISO 2768 T1 C (dimensions in mm)		
xx...6 (±0.3)	>30...120 (±0.8)	>400...1000 (±2.0)
>6...30 (±0.5)	>120...400 (±1.2)	>1000...2000 (±3.0)

2.4.5 RT62X1 with MK6201

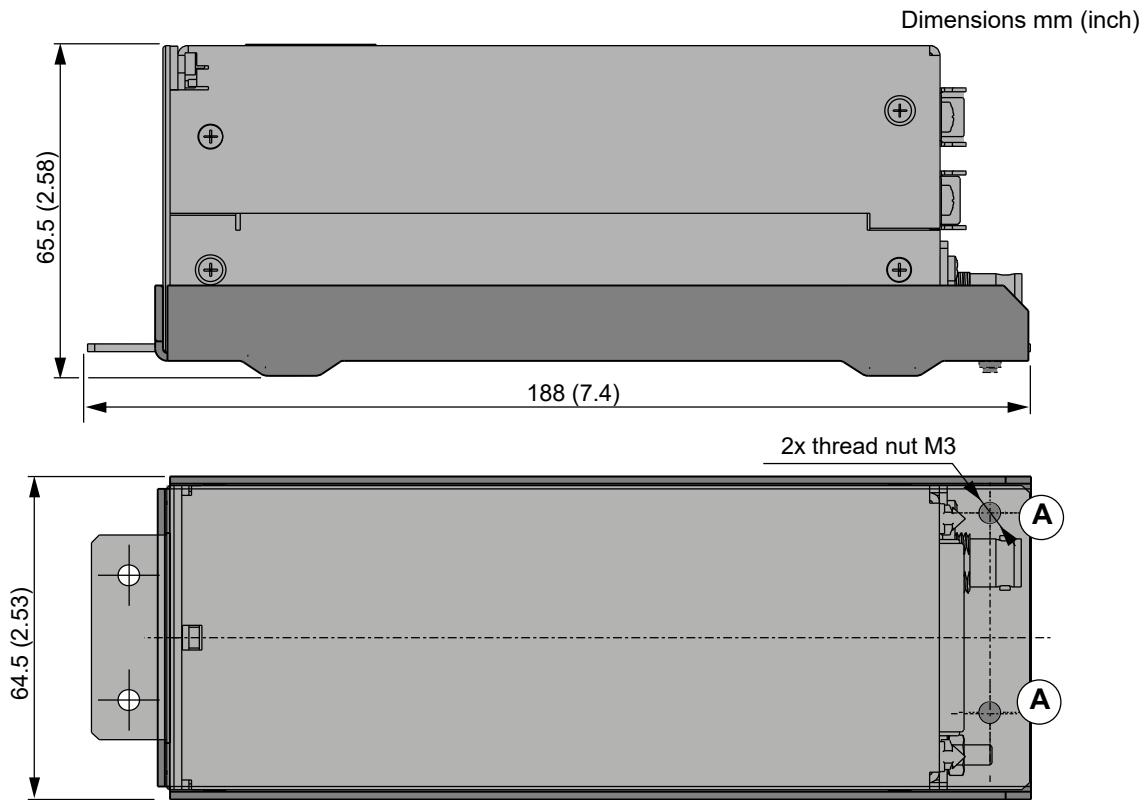
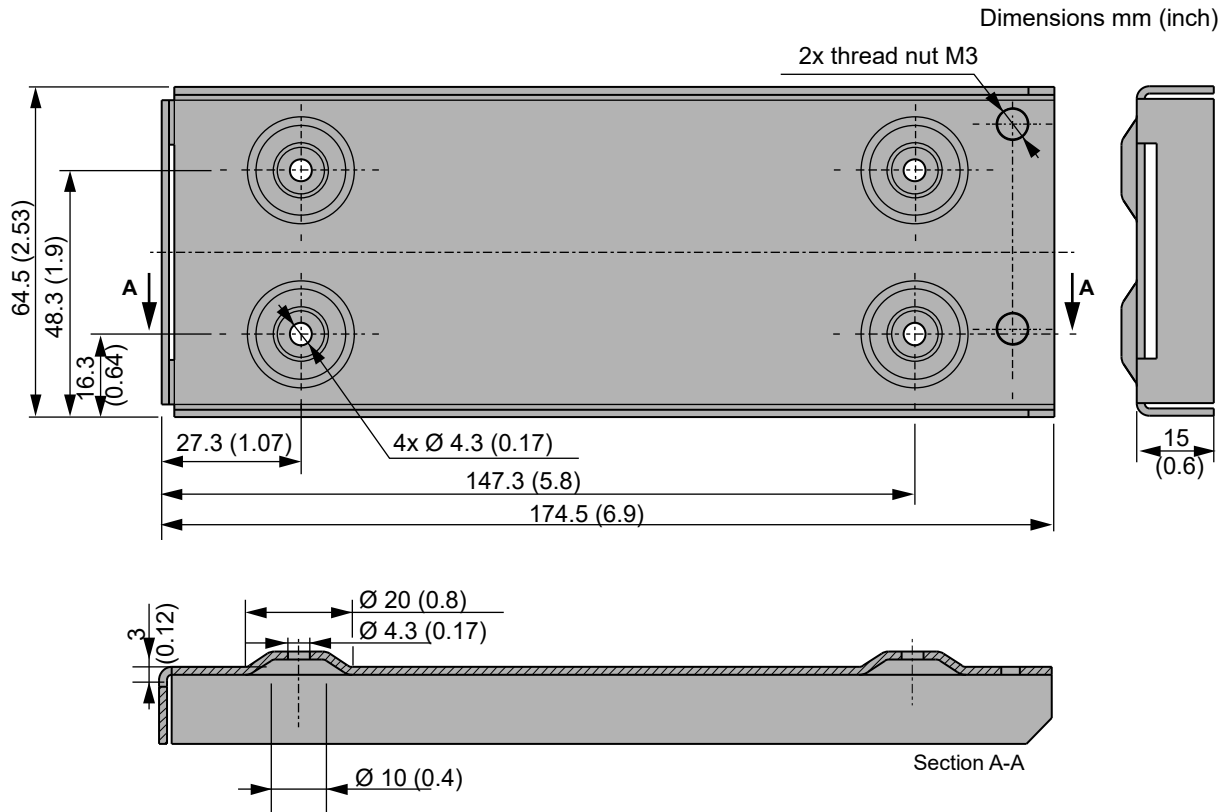

Figure 15: Dimensions - RT62X1 with mounting kit MK6201

2.4.6 Mounting kit - MK6201



B: 4x installation holes Ø 4.3 mm.

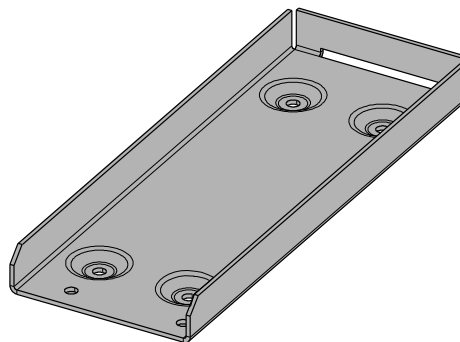

Figure 16: Dimensions - Mounting kit MK6201 (for RT62X1)

Permitted deviation for dimensions without tolerances: DIN ISO 2768 T1 C (dimensions in mm)		
xx...6 (±0.3)	>30...120 (±0.8)	>400...1000 (±2.0)
>6...30 (±0.5)	>120...400 (±1.2)	>1000...2000 (±3.0)

2.4.7 Mounting kit - MK6403-1

Dimensions mm (inch)

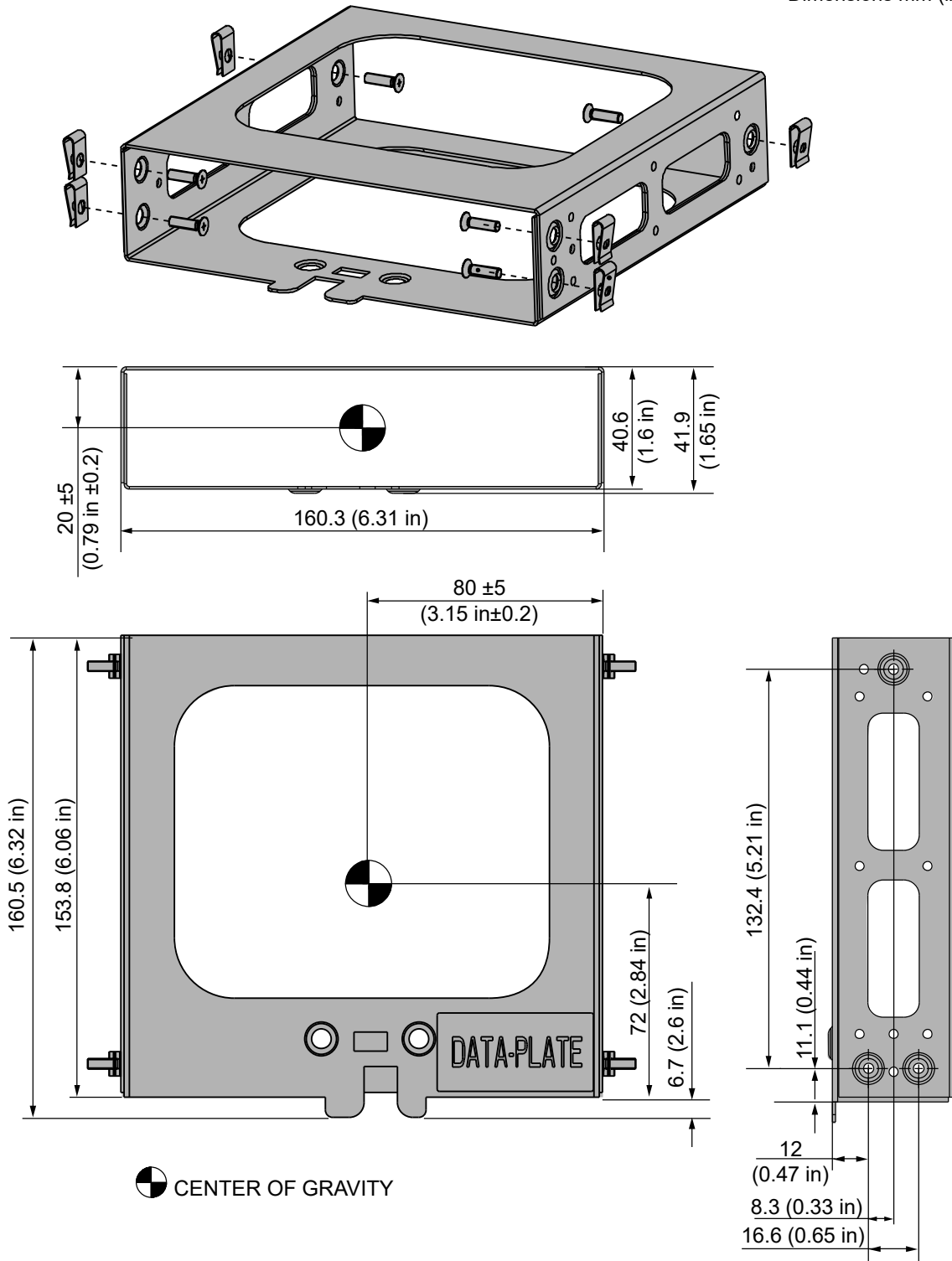
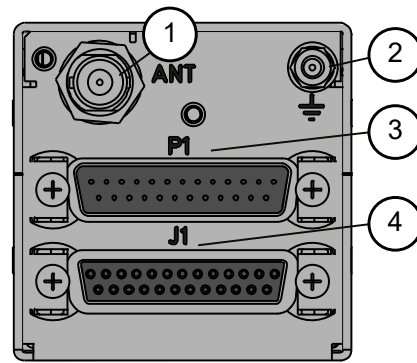

Figure 17: Dimensions - Mounting kit MK6403-1 (for AR62X3)

NOTICE "Center of Gravity" is without other equipment.

Permitted deviation for dimensions without tolerances: DIN ISO 2768 T1 C (dimensions in mm)		
xx...6 (±0.3)	>30...120 (±0.8)	>400...1000 (±2.0)
>6...30 (±0.5)	>120...400 (±1.2)	>1000...2000 (±3.0)

2.5 Connector Pin Assignments



- 1: Antenna connector
- 2: Grounding bolt
- 3: P1
- 4: J1

Figure 18: AR62X1, RT62X1 – Connector Layout

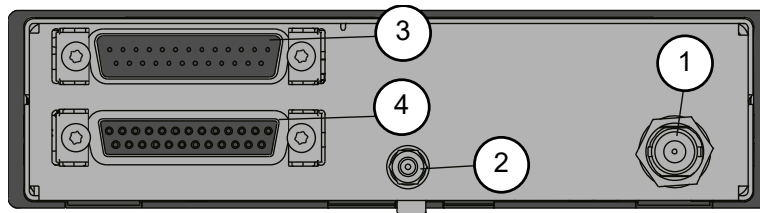

- 1: Antenna connector
- 2: Grounding bolt
- 3: P1
- 4: J1

Figure 19: AR62X3 – Connector Layout

2.5.1 Device Connectors (AR62XX, RT62X1)

Position 3 (P1)

- Type: 25pin D-Sub male connector with slide-in fastener.

Position 4 (J1)

- Type: 25pin D-Sub female connector with slide-in fastener.

2.5.2 Antenna Connector (AR62XX, RT62X1)

- The antenna connector is a BNC type.
- The antenna port is made for operating with a nominal impedance of 50 Ω .

2.5.3 Grounding Bolt (AR62XX, RT62X1)

- The transceivers have a M4 threaded grounding bolt at the rear side.
- Use this grounding bolt to make a low impedance grounding of the device.
 - Maximum tightening torque for ground stud screw is 1.5 Nm (14 inch-lbs).
 - Wire cross section: min. 4 mm².
 - Length: max. 150 mm (6 in).

Connector Pin Assignments

2.5.3.1 Connector P1 (System Interfaces)

P1 Pin	Name	I/O	Function
1	SPK_HI	OUT	Speaker output signal
2	HDPH1_A	OUT	Balanced output for headphone(s)1
3	HDPH1_B	OUT	Balanced output for headphone(s)1
4	AF_AUX_IN_HI	IN	Auxiliary audio input
5	MIKE_DYN_HI	IN	Balanced input for dynamic microphone(s)
6	MIKE_DYN_LO	IN	Balanced input for dynamic microphone(s)
7	/IC	IN	Intercom key input; ACTIVE state - closed contact to GND
8	MIKE_STD_LO	-	Standard microphone(s) low (ground) used for STD1, STD2 and STD3
9	MIKE_STD2_HI	IN	Standard microphone 2 High
10	ILL_LO	IN	Illumination low input
11	P_SUPP	IN	Power supply (positive)
12	P_SUPP	IN	Power supply (positive)
13	P_SUPP_GND	-	Power supply ground
14	SPK_LO	-	Speaker ground
15	LINE_OUT	OUT	Linear audio output, unbalanced
16	AGC_OUT	OUT	Receiver AGC output
17	/PTT1	IN	Push To Talk key input1 ACTIVE state - closed contact to GND
18	MIKE_STD1_HI	IN	Standard Microphone 1 High
19	MIKE_STD3_HI	IN	Standard Microphone 3 High
20	HDPH2_A	OUT	Balanced Output for headphone(s)2
21	AF_AUX_IN_LO	IN	Auxiliary audio input low
22	HDPH2_B	OUT	Balanced output for headphone(s)2
23	ILL_HI	IN	Illumination high
24	/PWR_EVAL	OUT	Power on monitor output
25	P_SUPP_GND	-	Power supply ground

2.5.3.2 Connector J1 (System Interfaces, Discrete I/Os)

J1 Pin	Name	I/O	Function
1	CPIN	-	Reserved coding pin
2	TX2+	OUT	Auxiliary control interface
3	RX2+	IN	Auxiliary Control Interface
4	/SQL_EVAL	OUT	Squelch monitor output ACTIVE state - closed contact to GND
5	/PTT2	IN	Push-To-Talk key input 2 ACTIVE state - closed contact to GND
6	SHIELD_1	-	Secondary control & service interface SHIELD
7	TX1+	OUT	Secondary control & service interface
8	RX1+	IN	Secondary control & service interface
9	TX2-	OUT	Auxiliary control interface
10	RX2-	IN	Auxiliary control interface
11	SHIELD_2	-	Auxiliary control interface SHIELD
12	/EXT_SO	IN	External "Exchange" key Falling edge will activate frequency exchange
13	/SRV_EN	IN	Service enable pin ACTIVE state - closed contact to GND
14	TX1-	OUT	Secondary control & service interface
15	RX1-	IN	Secondary control & service interface
16	NC		not connected
17	/SQL_SW	IN	"Squelch Force-OFF" input ACTIVE state - closed contact to GND
18	NC		not connected
19	NC		not connected
20	/ISOL	IN	"ISOL" input ACTIVE state - closed contact to GND
21	D_GND	-	Discrete lines ground
22	D_GND	-	Discrete lines ground
23	D_GND	-	Discrete lines ground
24	/MIKE_SW	IN	Configuration selector CFG1 and CFG2
25	/EXT_ON	IN	External Power ON input ACTIVE state - closed contact to GND

2.5.4 Inputs / Outputs (AR62XX, RT62X1)

Microphone Connection – Standard Microphones

Pin No.	Pin Name	Direction	Function
P1-8	MIKE_STD_LO	-	Standard microphone(s) low used for STD1, STD2 and STD3
P1-9	MIKE_STD2_HI	IN	Standard microphone 2 high
P1-18	MIKE_STD1_HI	IN	Standard microphone 1 high
P1-19	MIKE_STD3_HI	IN	Standard microphone 3 high

- The transceiver has three unbalanced inputs STD1, STD2 and STD3.
- Each input has an input impedance of 150 Ω and a nominal sensitivity of 110 mV.
- The sensitivity level is adjustable in the configuration setup independently for each of the microphones.
- The power supply from pins P1-9, P1-18 and P1-19 for supply of the connected microphone(s) is > 8 VDC (8.3 V nominal) open circuit with an output impedance of 120 Ω .

Notice:

- The transceiver power supply can support two microphones in parallel on each of the three standard microphone inputs.
- It is recommended to combine only microphones of the same type / impedance.
- In installations where high interferences were detected, we recommend the use of sensitivity levels between 27...1500 mV.
- We also recommend to install the jacks generally isolated from car frame in order to prevent ground loops.

Microphone Connection - Dynamic Microphone

Pin No.	Pin Name	Direction	Function
P1-5	MIKE_DYN_HI	IN	Balanced input for dynamic microphone(s)
P1-6	MIKE_DYN_LO	IN	Balanced input for dynamic microphone(s)

- Interfacing with dynamic microphones, the transceiver has balanced inputs with an impedance of 140 Ω and a nominal sensitivity of 1.6 mV.
- The sensitivity level is adjustable in the configuration setup.
- Two dynamic microphones in parallel may be connected (identical technical characteristics of the microphones are recommended).

Notice:

- In installations where high interferences are detected we recommend the use of sensitivity levels between 2...20 mV.
- We also recommend to install the jacks generally isolated from car frame in order to prevent ground loops.
- Use microphone cables with shielded wires.

Speaker Connection

Pin No.	Pin Name	Direction	Function
P1-1	SPK_HI	OUT	Speaker output signal
P1-14	SPK_LO	-	Speaker ground

- The speaker output supplies nominal 4 W into 4 Ω .

SAFETY INSTRUCTIONS

- The magnetic field of a speaker can affect the magnetic compass (see "Installation Requirements" page 47).

Headphone(s) Connection

Pin No.	Pin Name	Direction	Function
P1-2	HDPH1_A	OUT	Balanced output for headphone(s) 1
P1-3	HDPH1_B	OUT	Balanced output for headphone(s) 1
P1-20	HDPH2_A	OUT	Balanced output for headphone(s) 2
P1-22	HDPH2_B	OUT	Balanced output for headphone(s) 2

- The headphone 1 output is a balanced, transformer-coupled output providing nominal 300 mW into 75 Ω .
 - Use a shielded single wire for headphones requires an unbalanced output configuration. To get this connect P1-3 to GND.
- The headphone 2 output is a balanced output providing nominal 200 mW into 75 Ω .
- You can connect up to two headphones with phone-impedance of 300 Ω (or higher) in parallel on each circuit, therefore you can connect up to four headphones at the same time.
- We also recommend to install the jacks generally isolated from car frame in order to prevent ground loops.

CAUTION: The headphone 2 output shall be always floating (cannot be connected in unbalance configuration as headphone 1).

Panel Illumination

Pin No.	Pin Name	Direction	Function
P1-10	ILL_LO	IN	Illumination low input
P1-23	ILL_HI	IN	Illumination high input

- The VHF transceiver supplies illumination for the keys and the display.
- It depends on configuration if the illumination is controlled with front panel or externally.
- It depends on configuration if 14 or 28 V fixed illumination voltage is used or aircraft dimming-bus voltage is in operation.
 - Connect ILL_LO (pin P1-10) to aircraft ground.
 - Connect ILL_HI (pin P1-23) to dimming bus.

"Auxiliary" Audio Input

Pin No.	Pin Name	Direction	Function
P1-4	AF_AUX_IN_HI	IN	Auxiliary audio input
P1-21	AF_AUX_IN_LO	-	Auxiliary audio input low

- The AF auxiliary input is used to connect an external audio source (NAV, music-player, etc.) to the transceiver.
- The external audio is audible only when transceiver is in receive mode.
- The input sensitivity is adjustable in the configuration setup.
- The impedance of this input is 600 Ω .

"LINE_OUT" Audio Output

Pin No.	Pin Name	Direction	Function
P1-14	SPK_LO	-	Speaker ground
P1-15	LINE_OUT_HI	OUT	Linear audio output, unbalanced

- The LINE OUT is used to connect e.g. an external voice recorder to the transceiver.
- The LINE OUT output supplies nominal 1 V_{RMS} into 1000 Ω .

Connector Pin Assignments

External Power ON

Pin No.	Pin Name	Direction	Function
J1-25	/EXT_ON	IN	External Power ON input ACTIVE state - closed contact to GND

- With the External Power ON input it is possible to power "ON" the system when this pin is connected to ground.

Push-To-Talk (/PTT)

Pin No.	Pin Name	Direction	Function
P1-17	/PTT1	IN	Push-To-Talk key input 1 ACTIVE state - closed contact to GND
J1-5	/PTT2	IN	Push-To-Talk key input 2 ACTIVE state - closed contact to GND

- There are two Push-To-Talk inputs available /PTT1 and /PTT2 (e.g. one for the pilot and one for the co-pilot).
- Each input has an internal pull up.
- While the input is connected to ground a current of < 1 mA flows.
 - The transceiver enters transmit operation, if one or both inputs are connected to ground.
- According to microphone(s) configuration, the signal from particular inputs can or cannot modulate transmissions.

Power Indication (/PWR_EVAL)

Pin No.	Pin Name	Direction	Function
P1-24	/PWR_EVAL	OUT	Power on monitor output: Device "OFF" - open circuit Device "ON" - closed circuit to GND (max. 100 mA)

- This output shows the transceiver status, "ON" or "OFF", with an open collector function.
- The output internally connects to ground when the device is "ON".
- A current of maximum 100 mA can flow to drive e.g. an external relay.
- The output has high impedance if the device is "OFF".

Notice: Connect a protection diode in parallel to the external relay to prevent damage of this output.

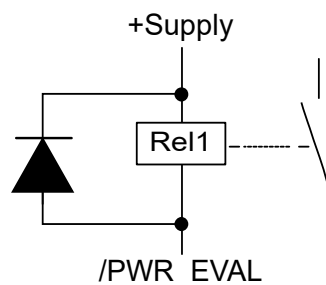
**VHF Channel Signal Indication (/SQL_EVAL)**

Pin No.	Pin Name	Direction	Function
J1-4	/SQL_EVAL	OUT	Indicates presence of the VHF channel's signal on the audio outputs.

- It is an open collector output type.
- The output internally connects to ground when the device receives signal on the selected VHF channel and this audio signal is available on audio outputs.
- A current of maximum 100 mA can flow to drive e.g. an external relay.
- The output has high impedance if the device is turned off.

External Mike Switch (/MIKE_SW)

Pin No.	Pin Name	Direction	Function
J1-24	/MIKE_SW	IN	Configuration selector CFG1 and CFG2. ACTIVE state - closed contact to GND

- The external mike switch is used for selection between the audio in/out configurations CFG1 and CFG2.
- When /MIKE_SW is active then configuration CFG2 is in use.
- When /MIKE_SW is inactive then CFG1 is in use.
- The configurations CFG1 and CFG2 contain parameters which are set in the configuration setup pages.
- You can change the configurations during the flight in the configuration setup.

External Intercom Key (IC)

Pin No.	Pin Name	Direction	Function
P1-7	IC	IN	Intercom key input; ACTIVE state - closed contact to GND

- This input has an internal pull up and is LO active.
- Start the intercom with P1-7 to GND:
 - When VOX does not work satisfactorily because of extreme loud cockpit environment caused e.g. by ambient noise.
 - When the speaker is enabled in current audio in/out configuration (configuration setup).
- For installations where automatic intercom operation starts with VOX, the connection of pin 7 is not necessary.
- While connected to ground, a current of max. 1 mA flows.

Isolation Mode (/ISOL)

Pin No.	Pin Name	Direction	Function
J1-20	/ISOL	IN	ISOL input for separation from co-pilot (passenger) ACTIVE state - closed contact to GND

- The transceivers have two microphone paths.
- You can connect two individual microphones to each microphone path.
- Depending on configuration, it is possible to connect pilot and co-pilot microphones on one path and two passenger microphones on the second path.
- When /ISOL is active (isolation mode); the passengers are isolated from the pilot intercom path and from the radio transmission, but they can communicate with each other.
- When /ISOL is inactive; both the pilot path and the passenger path are connected to one common intercom circuit.

Connector Pin Assignments

2.5.5 Device Connector (RCU62X1)

- Type: 15pin D-Sub male connector with slide-in fastener.

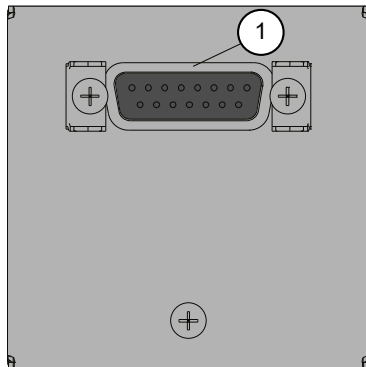

1: P1

Figure 20: RCU62X1 – Connector Layout

2.5.5.1 Connector P1

P1 Pin	Name	I/O	Function
1	TX0_422+	OUT	Primary Control & Service Interface
2	TX0_422-	OUT	Primary Control & Service Interface
3	RX1_422+	IN	Auxiliary Control Interface
4	RX0_422+	IN	Primary Control & Service Interface
5	RX0_422-	IN	Primary Control & Service Interface
6	ILL_LO	IN	Illumination low input
7	TX1_422-	OUT	Auxiliary Control Interface
8	ILL_HI	IN	Illumination high
9	GND	-	Power supply ground, shield for RS422, Ground for discrete lines
10	RX1_422-	IN	Auxiliary Control Interface
11	SUPP_IN	-	Power supply (positive)
12	/SRV_EN	OUT	Service enable pin ACTIVE state - closed contact to GND
13	/EXT_ON	IN	External Power ON input ACTIVE state - closed contact to GND
14	TX1_422+	OUT	Auxiliary Control Interface
15	/EXCH_CH	IN	External "Exchange" key ACTIVE state - closed contact to GND

2.5.6 Inputs / Outputs (RCU62X1)

Panel Illumination

Pin No.	Pin Name	I/O	Function
P1-6	ILL_LO	IN	Illumination low input
P1-8	ILL_HI	IN	Illumination high input

- These inputs are used for illumination of the keys and the display.
- It depends on configuration if the illumination is controlled with front panel or externally.
- For external configuration connect P1-6 to system ground and P1-8 to dimming voltage bus.

External Power ON (/EXT_ON)

Pin No.	Pin Name	I/O	Function
P1-13	/EXT_ON	IN/OUT	External Power ON input/output ACTIVE state - closed contact to GND

- This input/output is used to power on the system, for this connect P1-13 to ground.
- You can use this in installations with a central avionics power switch or to power on RT6201.

External Exchange (/EXCH_CH)

Pin No.	Pin Name	I/O	Function
P1-15	/EXCH_CH	IN	External "Exchange" key ACTIVE state - closed contact to GND

- This input is used to change active and preset frequency or activate SCAN mode with a switch.

2.6 Installation and Configuration

The minimum installation for the 62XX series transceivers is:

- Power supply.
- Antenna.
- Microphone (direct or with external audio panel).
- Headphone or speaker (direct or with external audio panel).
- Push-To-Talk (PTT) switch.

2.6.1 General Requirements

- For general instruction e.g. installation distance, cable types etc. please see "Installation Requirements" page 47.
- Type-specific cable harnesses are also available for the aircraft wiring (see "Accessories", page 41).
- No RF antenna cables or HF cables should be included in the cable harnesses of the system.
- Prevent routing of the cable harness along with other wiring, which carry audio power or pulses.

⚠ CAUTION

- Examine the wiring carefully before power up the device(s) and examine particularly correct connection of the power supply lines.

2.6.2 Customized Applications

Customized applications and wiring and configuration adjustments.

Applications	Reference
Single Seat Glider	page 88
Twin Seat Motor Glider	page 94
General Aviation (GA) Aircraft	page 96
Individual Dual Headset Installation (two IC Circuits)	page 98
Twin Seat with AR62XX (Tandem-Installation)	page 100
Four Seat Installation (no Tandem)	page 102
Installation with RT62X1 and RCU62X1	page 91
Installation in Aircraft with Intercom System	page 104
Twin Seat with RT62X1 (Tandem-Installation)	page 92

2.6.3 Antenna Installation

- A distance of ≥ 50 cm from the COM antenna to any installed GPS antenna is necessary and a distance as far away from any ELT antenna.
- Refer always to the manufacturer's instructions for antenna installation.
- Make the antenna installation in accordance with AC 43.13-2B Chapter 3.

NOTICE

For penetration of the pressurized cabin on a pressurized aircraft are additional data necessary which are not contained in this installation manual.

⚠ CAUTION**Radiation risk:**

A safe distance to the installed antenna must be ensured by corresponding installation measures around human body damage (e.g. at the eyes) and/or prevent the inflammation of combustible materials by radiated energy.

2.6.3.1 Antenna Type

Recommended antenna types:

- Vertical polarized 50 Ω broadband aircraft COM antenna.
- The antenna must be able to radiate RF energy evenly and omnidirectional.

2.6.3.2 Antenna Installation Details

- The aircraft-certifying inspector could support you in questions on how to achieve best results in all directions (installation instructions must be fully complied with).
- For aircraft with metal fuselage we recommend a rod antenna.
- The antenna should be installed vertically (as far as) on or under the fuselage.
- The antenna installation location should be of an even surface and in a safe distance from horizontally screening metal parts (propeller, undercarriage, vertical metal fins etc.), for maximum radio range in all (horizontal) directions.
- The VHF Com1 and VHF Com2 must be installed with at least $\frac{1}{2}$ wavelength (of the antenna operating frequency) distance between antennas. It is necessary to have an antenna separation of min. 45 dB.
- The distance to other aircraft antennas (COM, NAV antennas), should be at least 1.5 m.
- The antenna installation area should be as flat as possible.
- When two radios are used:
 - It is necessary to have an antenna separation of min. 45 dB. This must be guaranteed by the installer.
 - It could be that operational degradations may apply, this must be documented from the installer and approved for airworthiness.
- Make sure that the metallic contact between aircraft surface/structure and the antenna cable outer conductor (shield) is adequate/solid.
 - Never use a location on paint-coated surfaces!
 - The electrical contact must be continuously good safe against vibration.
- For wood and fiberglass (GRP) aircraft (reinforcing the mounting location):
 - 3 or 4 aluminum strips (each 60 cm long/5 cm wide) are recommended.
 - The stripes must be put (mostly) horizontally with a shape as a star or cross.
 - These counter weights must be centrally screwed together with the antenna socket to ensure a continuous, electrically good contact.
- For aircraft with non-metallic surface structure inside the fuselage:
 - A metal foil (min. 60x60 cm) can be stuck in.
 - The antenna socket must be installed in the foil center, in addition with a metallic ground contact support plate.
- For aircraft with fuselage and/or tail-fin made of non-conductive material:
 - A vertical folded top antenna is suitable.
 - The installation must be made preferably during manufacturing the tail-fin.

NOTICE

Notice:

Carbon fiber is conductive and can shield the antenna!

- Careful sealing of all holes/openings of the outer skin is mandatory.
 - Make sure, that electrical contacts are continuously good, even under bad environmental conditions.
 - Use only high quality 50 Ω coax cable type RG400 or higher quality.
 - Prevent any sharp cable bend (radius > 50 mm), and any excessive coax cable length.
 - Put all wiring including antenna cable away from other wiring which carries heavy AC currents and away from any aircraft controls.

Installation and Configuration

- Any operating kinematics, trimming and all control handles must be absolutely free in all directions.
- Ensure the BNC antenna plug is not shortened between inner and outer connector (ohmmeter).
 - A measured resistance of 0.0Ω shows a short inside antenna connector ($0.6...1 \Omega$ shows the antenna cable resistance), while an internally (static) protected antenna is used.
 - A simple rod antenna is tested for low resistive contact between inner cable conductor and radiator, and outer conductor to counter weight.
- Check the antenna matching:
 - Using 50Ω SWR meter over the whole frequency range for $VSWR \leq 3:1$.
 - It may be helpful or necessary to change slightly the length of the middle radiator, or counter weight length for optimized antenna efficiency and matching.

2.7 Configuration Setup

The configuration setup is for the configuration of installation and device parameters.

NOTICE We do not recommend to do changes on the configuration setup in-flight.

2.7.1 Configuration Interface

- Normally the configuration is done with the primary controller.
 - The primary controller at the single block devices AR62XX is the user interface directly connected to the transceiver.
 - The primary controller at the remote-controlled device RT62X1 is the one connected to primary control interface.
- If installed, the second controller (e.g. RCU62X1) must be turned off.
- The configuration on the second controller is only necessary if different adjustments for "BRIGHTNESS" or "ILLUMINATION CURVE" are necessary.
- After power on the second controller (e.g. RCU62X1) synchronizes the parameters with the parameters of the primary controller.
 - Any stored parameters in second controller will be overwritten.

2.7.2 Start Configuration Setup

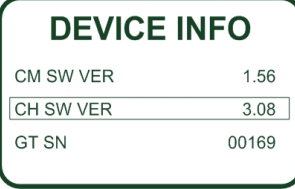
 <p>Figure 21: "PASSWORD"</p>	<ul style="list-style-type: none"> • Push and hold the "MDE" key during power up. <ul style="list-style-type: none"> ○ The configuration setup starts. ○ The display shows the screen "PASSWORD". • Insert the 4-digit numerical code password "6435" by turning and pushing the rotary encoder. • Push the "STO" key to complete the entry.
 <p>Figure 22: "DECIVE INFO"</p>	<ul style="list-style-type: none"> • The first page of configuration setup shows the "DEVICE INFO" screen.

2.7.2.1 Navigate between Pages

Page Down (next page):	<ul style="list-style-type: none"> • Push "↑/SCN" or use the rotary encoder.
Page Up (page before):	<ul style="list-style-type: none"> • Push "IC/SQL" key.
	<ul style="list-style-type: none"> • Use the rotary encoder for navigation in the sub-pages.

2.7.2.2 Store Setup Data

- The change of any parameter is stored immediately.

2.7.2.3 Cancel the Configuration Setup

- Turn "OFF" the device to stop the setup.
 - All changes made up to this time are stored automatically.

2.7.3 Volume Adjustment (VU Meter)

- The VU meter is to correct the adjustment of audio input sensitivity.
 - It is shown on all sensitivity adjustment menus.

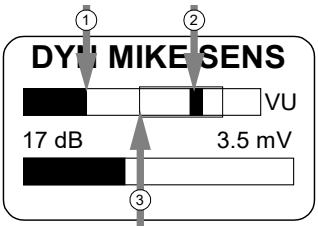
Display Contents	Description
<p>Example:</p>  <p>1: Current audio level 2: Hold max. level 3: Recommended range (inside frame)</p>	<ul style="list-style-type: none"> • The VU meter is shown in the middle below the menu name and above the sensitivity adjustment bar. • It shows the current audio level value on selected audio input ("Current audio level") • It holds the highest value of active audio level recorded during last 3 s (shown as "Hold max level" bar). • Correct sensitivity is achieved if most of the time, while you are speaking normally into the microphone, the "Hold max level" bar is in the "Recommended range".

2.7.4 Device Info

Display Contents	Description
<div style="border: 1px solid black; border-radius: 10px; padding: 10px;"> <p>DEVICE INFO</p> <p>CM SW VER 2.06</p> <p>CH SW VER 4.06</p> <p>AR SN 03665</p> </div>	<p>"DEVICE INFO":</p> <ul style="list-style-type: none"> • After the confirmation of the password the first page "DEVICE INFO" is shown. • This page shows information about the SW version and the serial number of the transceiver. <p>Example: For AR620X</p> <ul style="list-style-type: none"> • Transceiver SW version (CM SW VER). • Controller SW version (CH SW VER). • AR serial number (AR SN).
<div style="border: 1px solid black; border-radius: 10px; padding: 10px;"> <p>DEVICE INFO</p> <p>CM SW VER 2.06</p> <p>CH SW VER 4.06</p> <p>CM SN 00005</p> <p>CH SN 00005</p> </div>	<p>Example: For RCU62 as primary controller of an RT62</p> <ul style="list-style-type: none"> • Transceiver SW version (CM SW VER). • Controller SW version (CH SW VER). • RT62 serial number (CM SN). • RCU62 serial number (CH SN).
<div style="border: 1px solid black; border-radius: 10px; padding: 10px;"> <p>DEVICE INFO</p> <p>CH SW VER 4.06</p> <p>CH SN 00005</p> </div>	<p>Example: For RCU62 as secondary controller</p> <ul style="list-style-type: none"> • Controller SW version (CH SW VER). • RCU62 serial number (CH SN).

2.7.5 Dimming, Brightness

Display Contents	Description
<div style="border: 1px solid black; padding: 5px;"> <p>DIMMING INPUT</p> <ul style="list-style-type: none"> <input checked="" type="radio"/> NONE <input type="radio"/> 0-14V <input type="radio"/> 0-28V </div>	<p>"DIMMING INPUT":</p> <p>Notice: The menu is available on the primary and secondary controller.</p> <ul style="list-style-type: none"> • Three options are available. • Turn the rotary encoder to change illumination for the keys and the display. • Finalize the selection with a push on "STO" key. <p>NONE:</p> <ul style="list-style-type: none"> • The illumination is controlled with the rotary encoder on the transceiver itself. • The user can adjust the brightness in the user menu. <p>0...14 V or 0...28 V:</p> <ul style="list-style-type: none"> • The background lighting for LCD and keys is controlled by the dimming bus. • The dimming curve is adjustable in the range from 0...14 VDC respectively 0...28 VDC. • Adjustment of the brightness with the rotary encoder is no longer possible after selecting this option.
<div style="border: 1px solid black; padding: 5px;"> <p>BRIGHTNESS</p> <p style="text-align: center; font-size: 1.2em;">65</p> <div style="border: 1px solid black; width: 100%; height: 15px; margin: 5px 0;"> <div style="background-color: black; width: 65%;"></div> </div> <p style="text-align: center;">0% (off)... 100%</p> </div>	<p>"BRIGHTNESS":</p> <p>Notice: This page is shown only when the dimming input is set to "NONE". Otherwise the aircraft dimming bus controls the brightness.</p> <ul style="list-style-type: none"> • Use the rotary encoder to set the brightness. • The user can adjust the brightness in the user menu. • The user can change the parameter at any time. • The brightness adjustments are separate for each controller therefore this menu is available on all controllers.

2.7.6 Illumination Curve

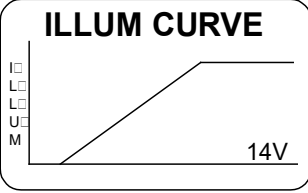
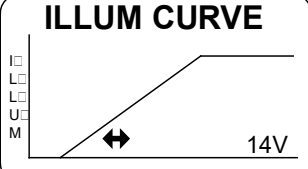
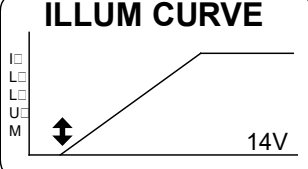
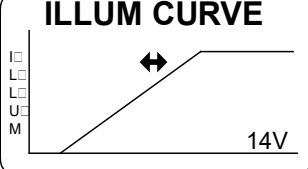
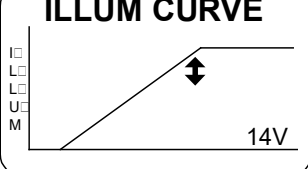
Display Contents	Description
	<p>"ILLUM CURVE":</p> <p>Notice: This page is shown only when the the DIMMING input is selected for "14 V or 28 V" dimming-bus voltage. The menu is available on the primary and secondary controller.</p> <ul style="list-style-type: none"> • The illumination curve shows the relation between dimming bus voltage and brightness of the LCD and key illumination. • Two adjustable points V1 and V2 define the illumination curve. • Push the "STO" key to select the parameter. • Adjust the value in horizontal (left/right), vertical (up/down) direction with the rotary encoder.
	<ul style="list-style-type: none"> • (1) This parameter specifies the horizontal parameter V1x (minimum values: 1.5 V for 14 V dimming bus and 4 V for 28 V dimming bus). • Up to this value the brightness is zero. • When reaching V1x the brightness is immediately adjusted to V1y.
	<ul style="list-style-type: none"> • (2) This parameter specifies the vertical parameter V1y which is the level of brightness that is set when the trigger point V1x is reached.
	<ul style="list-style-type: none"> • (3) This parameter specifies the horizontal parameter V2x (maximum values: 14 V or 28 V depending on selected dimming input) where the illumination curve reaches the maximum brightness level.
	<ul style="list-style-type: none"> • (4) This parameter specifies the vertical parameter V2y which is the maximum brightness.

2.7.7 Memory Options

Display Contents	Description
<div style="border: 1px solid black; border-radius: 10px; padding: 10px; width: fit-content;"> <p style="text-align: center;">MEM OPTIONS</p> <p><input checked="" type="checkbox"/> CHANNEL STORE</p> <p><input checked="" type="checkbox"/> STORE LAST CHANNELS</p> </div>	<p>"MEM OPTIONS": Notice: The menu is available on the primary and secondary controller.</p> <ul style="list-style-type: none"> • Two options are available: • Select the option with the rotary encoder. • Push the "STO" key to enabled/ disabled it. <p>CHANNEL STORE:</p> <ul style="list-style-type: none"> • If this option is enabled the user can store frequencies in any of the 99 available channels. • If this option is disabled the user has access only to stored channels. <p>STORE LAST CHANNELS:</p> <ul style="list-style-type: none"> • If this option is enabled, the device automatically stores the last used VHF frequency in the "Last Channel" database and the user has access to these channels. • If this option is disabled the user has no access to these channels.

2.7.8 Modification, Battery

Display Contents	Description
<div style="border: 1px solid black; border-radius: 10px; padding: 10px; width: fit-content;"> <p style="text-align: center;">MDE PAGES</p> <p><input checked="" type="checkbox"/> STANDBY FREQUENCY</p> <p><input checked="" type="checkbox"/> BATTERY VOLTAGE</p> <p><input checked="" type="checkbox"/> CHANNEL MEMORY</p> </div>	<p>"MDE PAGES": Notice: The menu is available on the primary and secondary controller.</p> <ul style="list-style-type: none"> • Three options are available: • The options support different user interfaces for the selection of the operating frequency. • Select the option with the rotary encoder. • Push the "STO" key to enabled/disabled it. <p>STANDBY FREQUENCY:</p> <ul style="list-style-type: none"> • Enables/disables "Standard Mode" <p>BATTERY VOLTAGE:</p> <ul style="list-style-type: none"> • Enables/disables "Direct Tune Mode". <p>CHANNEL MEMORY:</p> <ul style="list-style-type: none"> • Enables/disables "Channel Mode". • When "BATTERY VOLTAGE" is disabled the "DIRECT TUNE MODE" page is no longer available in the normal operation. • Store a frequency in a specific channel is possible even if only "BATTERY VOLTAGE" or "STANDBY FREQUENCY" is selected. • It is not possible to disable all options from the "MDE PAGES".
	<p>"LOW BATT THR": Notice: The menu is available on the primary and secondary controller.</p> <ul style="list-style-type: none"> • On this page you can adjust the threshold for indication of the "LOW BATT" warning page (default adjustment is 10.5 V). • The low battery threshold depends on battery type. • The low battery threshold is adjustable. • Use the rotary encoder for the adjustment. • The display shows the "LOW BATT" warning if the supply voltage is less than the "LOW BATT THR" value.

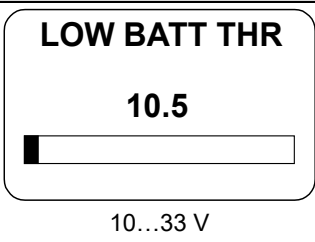
Display Contents	Description
 <p>LOW BATT THR</p> <p>10.5</p> <p>10...33 V</p>	<p>Recommended values:</p> <ul style="list-style-type: none"> "LOW BATT THR" = 11 V for 12 V battery "LOW BATT THR" = 24 V for 24 V battery

2.7.9 Configuration

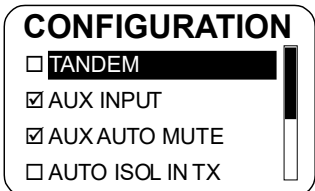
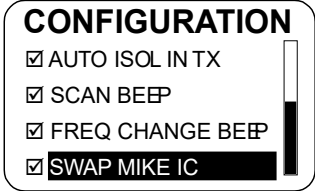
Display Contents	Description
 <p>CONFIGURATION</p> <p><input type="checkbox"/> TANDEM</p> <p><input checked="" type="checkbox"/> AUX INPUT</p> <p><input checked="" type="checkbox"/> AUX AUTO MUTE</p> <p><input type="checkbox"/> AUTO ISOL IN TX</p> <p>Options 1...4</p>	<p>"CONFIGURATION":</p> <ul style="list-style-type: none"> On this page 6...7 options are available. Select the option with the rotary encoder. Push the "STO" key to enabled/ disabled it. <p>TANDEM:</p> <ul style="list-style-type: none"> If this is selected it is possible to connect a second controller (e.g. RCU62) to the AR62/RT62. <p>AUX INPUT:</p> <ul style="list-style-type: none"> If selected, the auxiliary audio signal is audible on headphone / speaker (P1-4 / P1-21). Is the auxiliary audio input not used, it is recommended to disable "AUX INPUT".
 <p>CONFIGURATION</p> <p><input checked="" type="checkbox"/> AUTO ISOL IN TX</p> <p><input checked="" type="checkbox"/> SCAN BEEP</p> <p><input checked="" type="checkbox"/> FREQ CHANGE BEEP</p> <p><input checked="" type="checkbox"/> SWAP MIKE IC</p> <p>Options 4...7</p>	<p>AUX AUTO MUTE:</p> <p>Notice: "AUX AUTO MUTE" is only shown when "AUX INPUT" is enabled.</p> <ul style="list-style-type: none"> If selected the auxiliary audio input is muted. The auxiliary audio input is also muted if the receiver finds a signal (based on squelch evaluation). When disabled the auxiliary audio input signal and the receiver signal will intermix continuously. <p>AUTO ISOL IN TX:</p> <ul style="list-style-type: none"> If selected, a separation between the pilots and passenger intercom circuit is done while one of the pilots transmits. <p>SCAN BEEP:</p> <ul style="list-style-type: none"> If selected the transceiver supply a short beep tone to notify a signal presence on the "PRESET FREQUENCY" (only in scan function). During signal reception on the "ACTIVE FREQUENCY" a change to the "PRESET FREQUENCY" is not possible. The audio stays on "ACTIVE FREQUENCY" and a short beep tone is audible. The "PRESET FREQUENCY" value is shown inverted in a sequence of approximately 1 s. <p>FREQ CHANGE BEEP:</p> <ul style="list-style-type: none"> If selected the transceiver supply a short beep on each change of the "ACTIVE FREQUENCY". <p>SWAP MIKE IC:</p> <ul style="list-style-type: none"> If selected the /IC input functions as /MIKE_SW input and /MIKE_SW input operates as /IC input.

2.7.10 Auxiliary Audio Input

Display Contents	Description
<p>AUX IN SENS</p> <p>20 dB 800 mV</p> <p>50...8000 mV,</p>	<p>"AUX IN SENS":</p> <p>Notice: The menu is available on the primary and secondary controller.</p> <ul style="list-style-type: none"> On this page you can adjust the sensitivity of the auxiliary audio input (P1-4 / P1-21). Use the rotary encoder for the adjustment. This page is shown only when ENABLE_AUX_IN is activated. The VU meter shows the current signal level of the aux audio input and the highest signal value from the last 3 s.
<p>AUTO AUX ATT</p> <p>20</p> <p>0...40 dB</p>	<p>"AUTO AUX ATT":</p> <p>Notice: The menu is available on the primary and secondary controller.</p> <ul style="list-style-type: none"> On this page you can adjust the attenuation of the auxiliary audio input. Use the rotary encoder for the adjustment. When intercommunication is started (regardless of the activation: "VOX", or "/IC" discrete input) the signal from auxiliary audio input will be attenuated. When intercommunication is completed the auxiliary audio changes to its level before.

2.7.11 IN/OUT CFG1

Display Contents	Description
<p>IN/OUT CFG 1</p> <p>MICROPHONE 1</p> <ul style="list-style-type: none"> ○ STD 1 MIKE ○ STD 2 MIKE ○ STD 3 MIKE ● DYN MIKE ○ NONE <p>MICROPHONE 2</p> <ul style="list-style-type: none"> ○ STD 1 MIKE ○ STD 2 MIKE ○ STD 3 MIKE ○ DYN MIKE ● NONE <p>MIC ACTIVATION</p> <ul style="list-style-type: none"> <input checked="" type="checkbox"/> BOTH MIKES <p>OUTPUTS</p> <ul style="list-style-type: none"> <input checked="" type="checkbox"/> HEADPHONE 1 ○ HEADPHONE 2 ● SPEAKER ○ NONE 	<p>"IN/OUT CFG1":</p> <p>Notice: The menu is available on the primary controller.</p> <p>Notice: When MIKE_SW is connected both configurations CFG1 and CFG2 must be configured.</p> <ul style="list-style-type: none"> On this page you can configure the microphone inputs and headphone outputs for configuration CFG1. Select the option with the rotary encoder. <p>"MICROPHONE 1" (set only one of the options):</p> <p>STD1 MIKE:</p> <ul style="list-style-type: none"> Standard microphone input 1 is selected (P1-18/ P1-8). <p>STD2 MIKE:</p> <ul style="list-style-type: none"> Standard microphone input 2 is selected (P1-9/ P1-8). <p>STD3 MIKE:</p> <ul style="list-style-type: none"> Standard microphone input 3 is selected (P1-19/ P1-8). <p>DYN MIKE:</p> <ul style="list-style-type: none"> Dynamic microphone input is selected (P1-6/ P1-5). <p>NONE:</p> <ul style="list-style-type: none"> No microphone is used in microphone path 1. <p>"MICROPHONE 2" (set only one of the options):</p> <p>STD1 MIKE:</p> <ul style="list-style-type: none"> Standard microphone input 1 is selected (P1-18/ P1-8). <p>STD2 MIKE:</p> <ul style="list-style-type: none"> Standard microphone input 2 is selected (P1-9/ P1-8). <p>STD3 MIKE:</p> <ul style="list-style-type: none"> Standard microphone input 3 is selected (P1-19/ P1-8). <p>DYN MIKE:</p> <ul style="list-style-type: none"> Dynamic microphone input is selected (P1-6/ P1-5). <p>NONE:</p>

Display Contents	Description
	<ul style="list-style-type: none"> • No microphone is used in microphone path 2. <p>"MIC ACTIVATION"</p> <p>BOTH MIKES ENABLED:</p> <ul style="list-style-type: none"> • Input /PTT1 starts transmission from microphone path 1 and 2 (P1-17). • Input /PTT2 starts transmission from microphone path 2 and path 1 (J1-5). • Input /IC starts intercom from microphone path 1 and 2 (P1-7). <p>BOTH MIKES DISABLED:</p> <ul style="list-style-type: none"> • Input /PTT1 starts transmission only from microphone path 1 (P1-17). • Input /PTT2 starts transmission only from microphone path 2 (J1-5). • Input /IC starts intercom only from microphone path 1 (P1-7). <p>"OUTPUTS"</p> <p>HDPH 1 ENABLED:</p> <ul style="list-style-type: none"> • Audio is available on headphone 1 output (P1-2/P1-3). <p>HDPH 1 DISABLED:</p> <ul style="list-style-type: none"> • No audio is available on headphone 1 output. <p>HDPH 2 ENABLED:</p> <ul style="list-style-type: none"> • Audio is available on headphone 2 output (P1-20/P1-22), speaker is not available. <p>HDPH 2 DISABLED:</p> <ul style="list-style-type: none"> • No audio is available on headphone 2 output, speaker is not available. <p>SPEAKER ENABLED:</p> <ul style="list-style-type: none"> • Audio is available on speaker (P1-1/P1-14), headphone 2 is not available. <p>NONE:</p> <ul style="list-style-type: none"> • No audio on headphone 2 output or speaker output.

2.7.12 IN/OUT CFG2

Display Contents	Description
<div style="border: 1px solid black; padding: 5px;"> <p>IN/OUT CFG 2</p> <p>MICROPHONE 1 <input type="radio"/></p> <ul style="list-style-type: none"> <input type="radio"/> STD 1 MIKE <input type="radio"/> STD 2 MIKE <input type="radio"/> STD 3 MIKE <input checked="" type="radio"/> DYN MIKE <input type="radio"/> NONE <hr/> <p>MICROPHONE 2 <input type="radio"/></p> <ul style="list-style-type: none"> <input type="radio"/> STD 1 MIKE <input type="radio"/> STD 2 MIKE <input type="radio"/> STD 3 MIKE <input type="radio"/> DYN MIKE <input checked="" type="radio"/> NONE <p>MIC ACTIVATION</p> <p><input checked="" type="checkbox"/> BOTH MIKES</p> <p>OUTPUTS</p> <p><input type="checkbox"/> HEADPHONE 1</p> <ul style="list-style-type: none"> <input type="radio"/> HEADPHONE 2 <input type="radio"/> SPEAKER <input checked="" type="radio"/> NONE </div>	<p>"IN/OUT CFG2":</p> <p>Notice: The menu is available on the primary controller.</p> <p>Notice: "IN/OUT CFG2" is shown only when the MIKE_SW input has active state (J1-24 is connected to GND). When MIKE_SW is connected both configurations CFG1 and CFG2 must be configured.</p> <ul style="list-style-type: none"> • On this page you can configure the microphone inputs and headphone outputs for configuration CFG2. • Select the option with the rotary encoder. <p>"MICROPHONE 1" (set only one of the options):</p> <p>STD1 MIKE:</p> <ul style="list-style-type: none"> • Standard microphone input 1 is selected (P1-18/ P1-8). <p>STD2 MIKE:</p> <ul style="list-style-type: none"> • Standard microphone input 2 is selected (P1-9/ P1-8). <p>STD3 MIKE:</p> <ul style="list-style-type: none"> • Standard microphone input 3 is selected (P1-19/ P1-8). <p>DYN MIKE:</p> <ul style="list-style-type: none"> • Dynamic microphone input is selected (P1-6/ P1-5). <p>NONE:</p> <ul style="list-style-type: none"> • No microphone is used in microphone path 1. <p>"MICROPHONE 2" (set only one of the options):</p> <p>STD1 MIKE:</p> <ul style="list-style-type: none"> • Standard microphone input 1 is selected (P1-18/ P1-8). <p>STD2 MIKE:</p> <ul style="list-style-type: none"> • Standard microphone input 2 is selected (P1-9/ P1-8). <p>STD3 MIKE:</p> <ul style="list-style-type: none"> • Standard microphone input 3 is selected (P1-19/ P1-8). <p>DYN MIKE:</p> <ul style="list-style-type: none"> • Dynamic microphone input is selected (P1-6/ P1-5). <p>NONE:</p> <ul style="list-style-type: none"> • No microphone is used in microphone path 2. <p>"MIC ACTIVATION"</p> <p>BOTH MIKES ENABLED:</p> <ul style="list-style-type: none"> • Input /PTT1 starts transmission from microphone path 1 and 2 (P1-17). • Input /PTT2 starts transmission from microphone path 2 and 1 (J1-5). • Input /IC starts intercom from microphone path 1 and 2 (P1-7). <p>BOTH MIKES DISABLED:</p> <ul style="list-style-type: none"> • Input /PTT1 starts transmission only from microphone path 1 (P1-17). • Input /PTT2 starts transmission only from microphone path 2 (Pin J1-5). • Input /IC starts intercom only from microphone path 1(P1-7). <p>"OUTPUTS"</p> <p>HDPH 1 ENABLED:</p> <ul style="list-style-type: none"> • Audio is available on headphone 1 output (P1-2/P1-3). <p>HDPH 1 DISABLED:</p> <ul style="list-style-type: none"> • No audio is available on headphone 1 output. <p>HDPH 2 ENABLED:</p>

Display Contents	Description
	<ul style="list-style-type: none"> Audio is available on headphone 2 output (P1-20/P1-22), speaker is not available. <p>HDPH 2 DISABLED:</p> <ul style="list-style-type: none"> No audio is available on headphone 2 output, speaker is not available. <p>SPEAKER ENABLED:</p> <ul style="list-style-type: none"> Audio is available on speaker (P1-1/P1-14), headphone 2 is not available. <p>NONE:</p> <ul style="list-style-type: none"> No audio on headphone 2 output or speaker output.

2.7.13 Standard Microphone 1

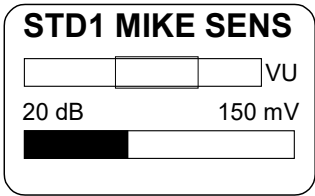
Display Contents	Description
 <p>9...1500 mV</p> <p>Notice: This page is shown only when: Standard Mike 1 input is selected in IN/OUT CFG1 and MIKE_SW input pin status is [Inactive] or Standard Mike 1 input is selected in IN/OUT CFG2 and MIKE_SW input pin status is [Active].</p>	<p>"STD1 MIKE SENS":</p> <p>Notice: The menu is available on the primary controller.</p> <ul style="list-style-type: none"> On this page the sensitivity of standard microphone 1 input is adjustable. Use the rotary encoder for the adjustment. The factory default adjustment is 119 mV. VU meter shows current value of audio level from standard microphone input 1 and the highest value of active audio level recorded during last 3 s. When speaking normally into the microphone the bar graph should stay in the recommended predefined range. <p>Notice: Adjust the microphone sensitivity and keep the cockpit noise suppression as high as possible, this make sure correct modulation.</p> <ul style="list-style-type: none"> If the sensitivity value is very small (e.g. 10 mV) more cockpit noise will be heard than if the sensitivity value is set to a higher level (e.g. 100 mV). If the sensitivity value is very high (e.g. 1000 mV) the cockpit noise is very decreased but the modulation of the transmitter may not be sufficient. Make a communication check after modification of this parameter. <ul style="list-style-type: none"> It is recommended to do this communication check with and without a running engine. <p>Notice: For installations with high interferences it is recommended to use sensitivity level from 27...1500 mV.</p>

2.7.14 Standard Microphone 2

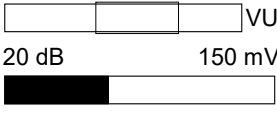
Display Contents	Description
<div data-bbox="165 488 478 678" style="border: 1px solid black; padding: 5px; margin-bottom: 10px;"> <p>STD2 MIKE SENS</p>  <p>9...1500 mV</p> </div> <p>Notice: This page is shown only when:</p> <p>Standard Mike 2 input is selected in IN/OUT CFG1 and MIKE_SW input pin status is [Inactive]</p> <p>or</p> <p>Standard Mike 2 input is selected in IN/OUT CFG2 and MIKE_SW input pin status is [Active].</p>	<p>"STD2 MIKE SENS":</p> <p>Notice: The menu is available on the primary controller.</p> <ul style="list-style-type: none"> On this page the sensitivity of standard microphone 2 input is adjustable. Use the rotary encoder for the adjustment. The factory default adjustment is 119 mV. VU meter shows current value of audio level from standard microphone input 2 and the highest value of active audio level recorded during last 3 s. When speaking normally into the microphone the bar graph should stay in the recommended predefined range. <p>Notice: Adjust the microphone sensitivity and keep the cockpit noise suppression as high as possible, this make sure correct modulation.</p> <ul style="list-style-type: none"> If the sensitivity value is very small (e.g. 10 mV) more cockpit noise will be heard than if the sensitivity value is set to a higher level (e.g. 100 mV). If the sensitivity value is very high (e.g. 1000 mV) the cockpit noise is very decreased but the modulation of the transmitter may not be sufficient. Make a communication check after modification of this parameter. <ul style="list-style-type: none"> It is recommended to do this communication check with and without a running engine. <p>Notice: For installations with high interference it is recommended to use sensitivity level from 27...1500 mV.</p>

2.7.15 Standard Microphone 3

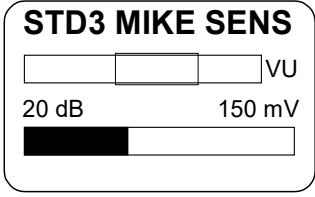
Display Contents	Description
 <p>9...1500 mV</p> <p>Notice: This page is shown only when: Standard Mike 3 input is selected in IN/OUT CFG1 and MIKE_SW input pin status is [Inactive] or Standard Mike 3 input is selected in IN/OUT CFG2 and MIKE_SW input pin status is [Active].</p>	<p>"STD3 MIKE SENS": Notice: The menu is available on the primary controller.</p> <ul style="list-style-type: none"> On this page the sensitivity of standard microphone 3 input is adjustable. Use the rotary encoder for the adjustment. The factory default adjustment is 119 mV. VU meter shows current value of audio level from standard microphone input 3 and the highest value of active audio level recorded during last 3 s. Correct sensitivity is achieved when you are speaking normally into the microphone and the "Hold max level" bar stays in "recommended range". <p>Notice: Adjust the microphone sensitivity and keep the cockpit noise suppression as high as possible, this make sure correct modulation.</p> <ul style="list-style-type: none"> If the sensitivity value is very small (e.g. 10 mV) more cockpit noise will be heard than if the sensitivity value is set to a higher level (e.g. 100 mV). If the sensitivity value is very high (e.g. 1000 mV) the cockpit noise is very decreased but the modulation of the transmitter may not be sufficient. Make a communication check after modification of this parameter. <ul style="list-style-type: none"> It is recommended to do this communication check with and without a running engine. <p>Notice: For installations with high interferences it is recommended to use sensitivity level 27...1500 mV.</p>

2.7.16 Dynamic Microphone

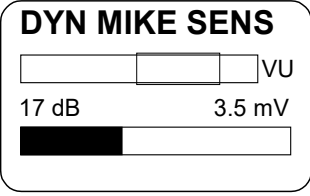
Display Contents	Description
<div style="border: 1px solid black; padding: 5px; margin-bottom: 10px;"> <p>DYN MIKE SENS</p>  <p>0.5...25 mV</p> </div> <p>Notice: This page is only shown when: Dynamic Mike input is selected in IN/OUT CFG1 and MIKE_SW input pin status is [inactive] or Dynamic Mike input is selected in IN/OUT CFG2 and MIKE_SW input pin status is [active].</p>	<p>"DYN MIKE SENS": Notice: The menu is available on the primary controller.</p> <ul style="list-style-type: none"> On this page the sensitivity of dynamic mike sense input is adjustable. Use the rotary encoder for the adjustment. The factory default adjustment is 3.5 mV. When speaking normally into the microphone the bar graph should stay in the recommended predefined range. <p>Notice: Adjust the microphone sensitivity and keep the cockpit noise suppression as high as possible, this make sure correct modulation.</p> <ul style="list-style-type: none"> If the sensitivity value is very small (e.g. 1 mV) the cockpit noises will be heard than if the sensitivity value is set to a higher level (e.g. 25 mV). If the sensitivity value is very high (e.g. 25 mV), the cockpit noise is very decreased but the modulation of the transmitter may not be sufficient. Make a communication check after modification of this parameter. <ul style="list-style-type: none"> It is recommended to do this communication check with and without a running engine. <p>Notice: For installations with high interferences it is recommended to use sensitivity level 2...25 mV.</p>

2.7.17 Speaker

Display Contents	Description
<div style="border: 1px solid black; padding: 5px; margin-bottom: 10px;"> <p>SPKR VOL SRC</p> <ul style="list-style-type: none"> ○ PRIMARY CH ○ SECONDARY CH ● BOTH </div>	<p>"SPKR VOL SRC": Notice: The menu is available on the primary controller.</p> <ul style="list-style-type: none"> On this page three options are available. Select the option with the rotary encoder. Push the "STO" key to enabled/ disabled it. <p>PRIMARY CH:</p> <ul style="list-style-type: none"> If "PRIMARY CH" is selected the speaker volume is adjustable with AR6201/AR6203. <p>SECONDARY CH:</p> <ul style="list-style-type: none"> If " SECONDARY CH" is selected the speaker volume is adjustable with the secondary controller (e.g. RCU6201). <p>BOTH:</p> <ul style="list-style-type: none"> If " BOTH" is selected the speaker volume is adjustable with the arithmetic average value from the primary and secondary controller. <p>Notice: If the optional second controller (RCU6201) is not available then the SPKR VOLUME SOURCE must be set to the PRIMARY CH.</p>

2.7.18 Squelch

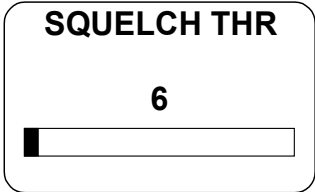
Display Contents	Description
 <p>SQUELCH THR</p> <p>6</p> <p>6...26</p>	<p>"SQUELCH THR":</p> <p>Notice: The menu is available on the primary controller.</p> <p>Notice: The "SQUELCH THR" is available with the "User Menu" at any time.</p> <ul style="list-style-type: none"> • Use the rotary encoder for the adjustment. <p>Minimum adjustment of 6 means:</p> <ul style="list-style-type: none"> • Weak RF signals can trigger the squelch threshold and the voice signal might be low combined with a noisy background. <p>Maximum adjustment of 26 means:</p> <ul style="list-style-type: none"> • Only strong RF signals will trigger the squelch threshold. The voice signal will be audible very clear with very low background noise. • Weak RF signals may not trigger the squelch threshold and therefore the audio may not be heard by the user.

2.7.19 Scan Hold Time

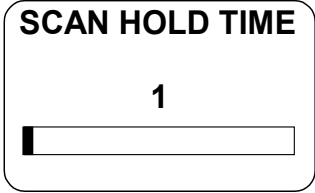
Display Contents	Description
 <p>SCAN HOLD TIME</p> <p>1</p> <p>1...60 s</p>	<p>"SCAN HOLD TIME":</p> <p>Notice: The menu is available on the primary controller.</p> <ul style="list-style-type: none"> • Use the rotary encoder for the adjustment. • The factory default adjustment is 1. • For normal operation it is recommended to keep this adjustment at 1.

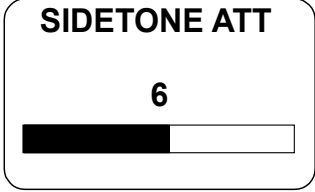

2.7.20 Sidetone

Display Contents	Description
 <p>SIDETONE ATT</p> <p>6</p> <p>0...12 dB</p>	<p>"SIDETONE ATT":</p> <p>Notice: The menu is available on the primary controller.</p> <ul style="list-style-type: none"> • Use the rotary encoder for the adjustment. • The attenuation relates to the intercom volume. <ul style="list-style-type: none"> ○ 0 dB = sidetone as loud as intercom signal. ○ 12 dB = sidetone signal 12 dB less than the intercom signal. <p>Example: If the intercom volume is set to a very low value, then the sidetone volume is decreased in relation to the intercom volume, irrespective of the sidetone value.</p> <p>The "SIDETONE ATT" parameter is an additional attenuation of the sidetone signal in transmit mode.</p>

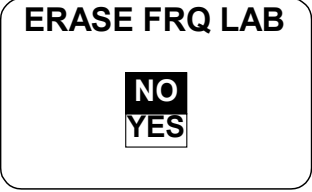
2.7.21 Erase Memory

Display Contents	Description
<p>ERASE CHN MEM</p> 	<p>"ERASE CHN MEM": Notice: The menu is available on the primary controller.</p> <ul style="list-style-type: none"> • The transceivers of the 62XX series have two databases to store VHF frequencies. <ul style="list-style-type: none"> ○ The "User Channels Database" identified by the channels numbers CH01...CH99. ○ The "Last Channels Database" " identified by the channels numbers LAST1...LAST9 (the last used frequencies). • You can erase the "User Channels Database" and the "Last Channels Database". <p>To erase the data bases:</p> <ul style="list-style-type: none"> • Select "YES" with the rotary encoder. • Push the "STO" key to confirm the selection.
<p>ERASE FRQ LAB</p> 	<p>"ERASE FRQ LAB": Notice: The menu is available on the primary controller.</p> <ul style="list-style-type: none"> • The transceivers of the 62XX series have a third database. • The "FRQUENCY LABELS DATABASE", it contains the text labels for the channels CH01...CH99. • You can erase the "LABELS DATABASE". <p>To erase the data base:</p> <ul style="list-style-type: none"> • Select "YES" with the rotary encoder. • Push the "STO" key to confirm the selection.

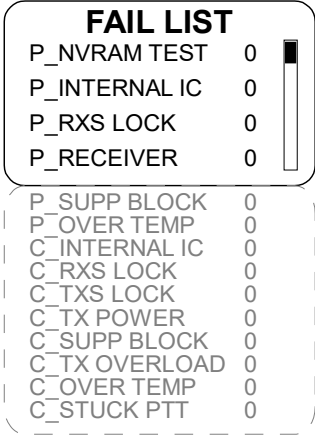
2.7.22 Fail List

Display Contents	Description
 <p>FAIL LIST</p> <p>P_NVRAM TEST 0</p> <p>P_INTERNAL IC 0</p> <p>P_RXS LOCK 0</p> <p>P_RECEIVER 0</p> <hr/> <p>P_SUPP BLOCK 0</p> <p>P_OVER TEMP 0</p> <p>C_INTERNAL IC 0</p> <p>C_RXS LOCK 0</p> <p>C_TXS LOCK 0</p> <p>C_TX POWER 0</p> <p>C_SUPP BLOCK 0</p> <p>C_TX OVERLOAD 0</p> <p>C_OVER TEMP 0</p> <p>C_STUCK PTT 0</p>	<p>"FAIL LIST":</p> <p>Notice: The menu is available on the primary controller.</p> <ul style="list-style-type: none"> This page shows information for all occurred and stored failures during operation. It is used for troubleshooting and failure isolation. The display can show 4 list entries at the same time. <ul style="list-style-type: none"> Use the rotary encoder to move the slide bar up/down to view the additional failures. "0" means no failure is occurred. "1" means a failure is occurred once or more times. <ul style="list-style-type: none"> The failure was stored in the fail list.
 <p>ERASE FAIL LIST</p> <p>NO</p> <p>YES</p>	<p>"ERASE FAIL LIST":</p> <p>Notice: The menu is available on the primary controller.</p> <p>To erase all stored failure entries:</p> <ul style="list-style-type: none"> Select "YES" with the rotary encoder. Push the "STO" key to confirm. <p>Notice:</p> <ul style="list-style-type: none"> The fail list can be erased after the installation and configuration work. The fail list should be not erased before a maintenance or repair work. The fail list helps to find the error cause. <ul style="list-style-type: none"> The failure list will be erased by factory or maintenance shop after a maintenance or repair is completed.

2.7.23 Recall Default Settings



Display Contents	Description
 <p>RECALL DEF.</p> <p>NO</p> <p>YES</p>	<p>"RECALL DEF":</p> <p>Notice: The menu is available on the primary controller.</p> <ul style="list-style-type: none"> The factory default settings are settings of the device after production. <p>To restore the factory default settings:</p> <ul style="list-style-type: none"> Select "YES" with the rotary encoder. Push the "STO" key to confirm. <p>Notice: Before stored data will be overwritten.</p>

Factory Default Settings

2.8 Factory Default Settings

Enabled Disabled Selected De-Selected

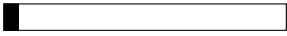
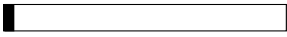
Adjustment name	Value
DEVICE INFO	
DIMMING INPUT	NONE
BRIGHTNESS	50%
MEMORY OPTIONS	<input checked="" type="checkbox"/> CHANNEL STORE <input checked="" type="checkbox"/> STORE LAST CHANNEL
MDE PAGES	<input checked="" type="checkbox"/> STANDBY FREQUENCY <input checked="" type="checkbox"/> BATTERY VOLTAGE <input checked="" type="checkbox"/> CHANNEL MEMORY
LOW BATT THR	10.5 V: AR6201-, AR6203-, RT6201-(X2X) 21.0 V: AR6201-, AR6203-, RT6201-(X1X)
CONFIG	<input type="checkbox"/> TANDEM <input type="checkbox"/> AUX_IN <input checked="" type="checkbox"/> AUTO ISOL IN TX <input type="checkbox"/> SCAN BEEP <input type="checkbox"/> FREQ CHANGE BEEP <input type="checkbox"/> SWAP MIKE IC
IN/OUT CFG1	MICROPHONE 1 <input checked="" type="radio"/> STD 1 MIKE <input type="radio"/> STD 2 MIKE <input type="radio"/> STD 3 MIKE <input type="radio"/> DYN MIKE <input type="radio"/> NONE MICROPHONE 2 <input type="radio"/> STD 1 MIKE <input type="radio"/> STD 2 MIKE <input type="radio"/> STD 3 MIKE <input checked="" type="radio"/> DYN MIKE <input type="radio"/> NONE MIC ACTIVATION <input checked="" type="checkbox"/> BOTH MIKES OUTPUTS <input checked="" type="checkbox"/> HEADPHONE 1 <input type="checkbox"/> HEADPHONE 2 <input checked="" type="radio"/> SPEAKER <input type="radio"/> NONE

Adjustment name	Value
IN/OUT CFG2	<p>MICROPHONE 1</p> <ul style="list-style-type: none"> <input checked="" type="radio"/> STD 1 MIKE <input type="radio"/> STD 2 MIKE <input type="radio"/> STD 3 MIKE <input type="radio"/> DYN MIKE <input type="radio"/> NONE <p>MICROPHONE 2</p> <ul style="list-style-type: none"> <input type="radio"/> STD 1 MIKE <input checked="" type="radio"/> STD 2 MIKE <input type="radio"/> STD 3 MIKE <input type="radio"/> DYN MIKE <input type="radio"/> NONE <p>MIC ACTIVATION</p> <ul style="list-style-type: none"> <input checked="" type="checkbox"/> BOTH MIKES <p>OUTPUTS</p> <ul style="list-style-type: none"> <input checked="" type="checkbox"/> HEADPHONE 1 <input checked="" type="radio"/> HEADPHONE 2 <input type="radio"/> SPEAKER <input type="radio"/> NONE
STD1 MIKE SENS	119 mV
STD2 MIKE SENS	119 mV
STD3 MIKE SENS	119 mV
DYN MIKE SENS	3.5 mV
SPKR VOL SRC	<ul style="list-style-type: none"> <input checked="" type="radio"/> PRIMARY CH <input type="radio"/> SECONDARY CH <input type="radio"/> BOTH
SQUELCH THR	<p style="text-align: center;">12</p> 
SCAN HOLD TIME	<p style="text-align: center;">1</p> 
SIDETONE ATT	<p style="text-align: center;">6</p> 
EREASE CHANNEL MEM	<p>NO</p> <p>YES</p>
EREASE FREQUENCY LABELS	<p>NO</p> <p>YES</p>
FAIL LIST	
EREASE FAIL LIST	<p>NO</p> <p>YES</p>
RECALL DEF.	<p>NO</p> <p>YES</p>

2.9 Aircraft Wiring

SAFETY INSTRUCTIONS

The installation of the device(s) depends on the type of aircraft and its equipment and therefore only general information can be given in this section.

2.9.1 Electrical Bonding and Grounding

SAFETY INSTRUCTIONS

- Make sure that the device is correctly connected to aircraft ground (structure).
- Make sure that the electrical continuity between the device and the structure is also achieved without removing the protective finish at the attachment points.
- Make sure that the electrical bonding area is adequately sealed or coated in order to prevent corrosion.
- Make sure that the resistance between the component which ensure equipment bonding and any point of this item of equipment do not exceed 20 mΩ.

2.9.2 Single Seat Glider

2.9.2.1 Configuration - Single Seat Glider

Sub-Menu	Function/Selection										
"SPKR VOLUME SOURCE"	PRIMARY CH										
"IN/OUT CFG1":	<table border="0"> <tr> <td>"MICROPHONE 1"</td> <td>NONE</td> </tr> <tr> <td>"MICROPHONE 2"</td> <td>DYN_MIKE</td> </tr> <tr> <td>"BOTH MIKES"</td> <td>Enabled</td> </tr> <tr> <td>"HEADPHONE 1"</td> <td>Enabled</td> </tr> <tr> <td>"SPEAKER"</td> <td>Enabled</td> </tr> </table> <ul style="list-style-type: none"> • With /MIKE_SW not connected (/MIKE_SW input is set to Inactive state) it is only necessary to configure IN/OUT CFG1. • If only headphone(s) are used, SPEAKER can be disabled by selecting NONE. • If only the speaker is used, disable HDPH 1. 	"MICROPHONE 1"	NONE	"MICROPHONE 2"	DYN_MIKE	"BOTH MIKES"	Enabled	"HEADPHONE 1"	Enabled	"SPEAKER"	Enabled
"MICROPHONE 1"	NONE										
"MICROPHONE 2"	DYN_MIKE										
"BOTH MIKES"	Enabled										
"HEADPHONE 1"	Enabled										
"SPEAKER"	Enabled										
<div style="border: 1px solid black; padding: 5px;"> <p>DYN MIKE SENS</p> </div>	<ul style="list-style-type: none"> • Adjust DYN MIKE SENS to proper level 										
<div style="border: 1px solid black; padding: 5px;"> <p>CONFIGURATION</p> <p><input type="checkbox"/> TANDEM</p> <p><input checked="" type="checkbox"/> AUX INPUT</p> <p><input checked="" type="checkbox"/> AUX AUTO MUTE</p> <p><input type="checkbox"/> AUTO ISOL IN TX</p> </div>	<ul style="list-style-type: none"> • If you want to use an auxiliary input, we recommend to configure AUX AUTO MUTE in the CONFIGURATION: <ul style="list-style-type: none"> ○ "AUX IN" Enabled ○ "AUX AUTO MUTE" Enabled 										
"IN/OUT CFG2"	N/A										
Remarks:	<ul style="list-style-type: none"> • The speaker symbol is permanent shown on the display. • VOX operation is suppressed. 										

2.9.2.2 Wiring - Single Seat Glider

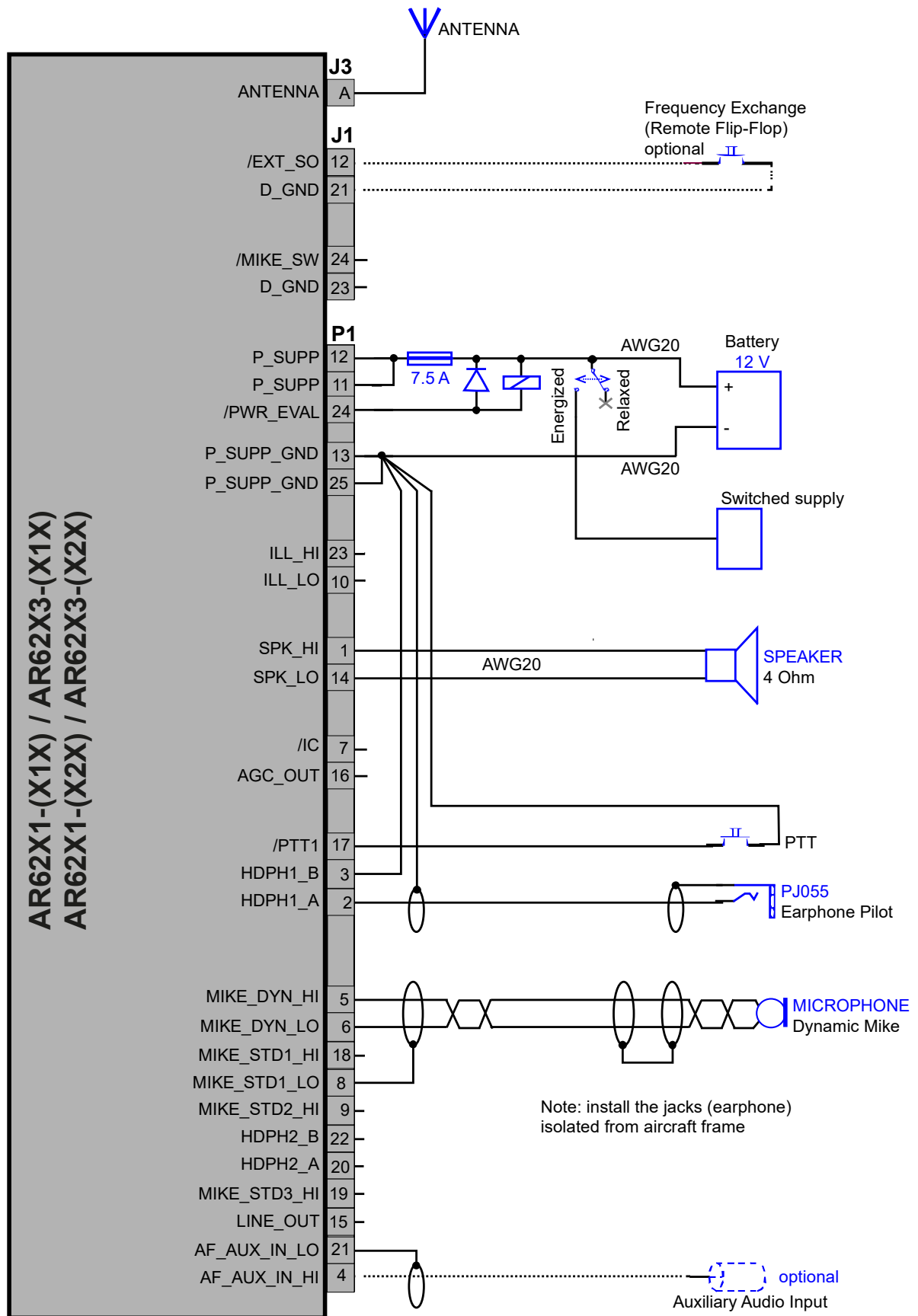

Figure 23: Wiring - Single Seat Glider

Notice: Frequency exchange switch and turned supply relay are optional.

2.9.2.3 Wiring - Single Seat Glider Installation with 5-pol DIN Jack

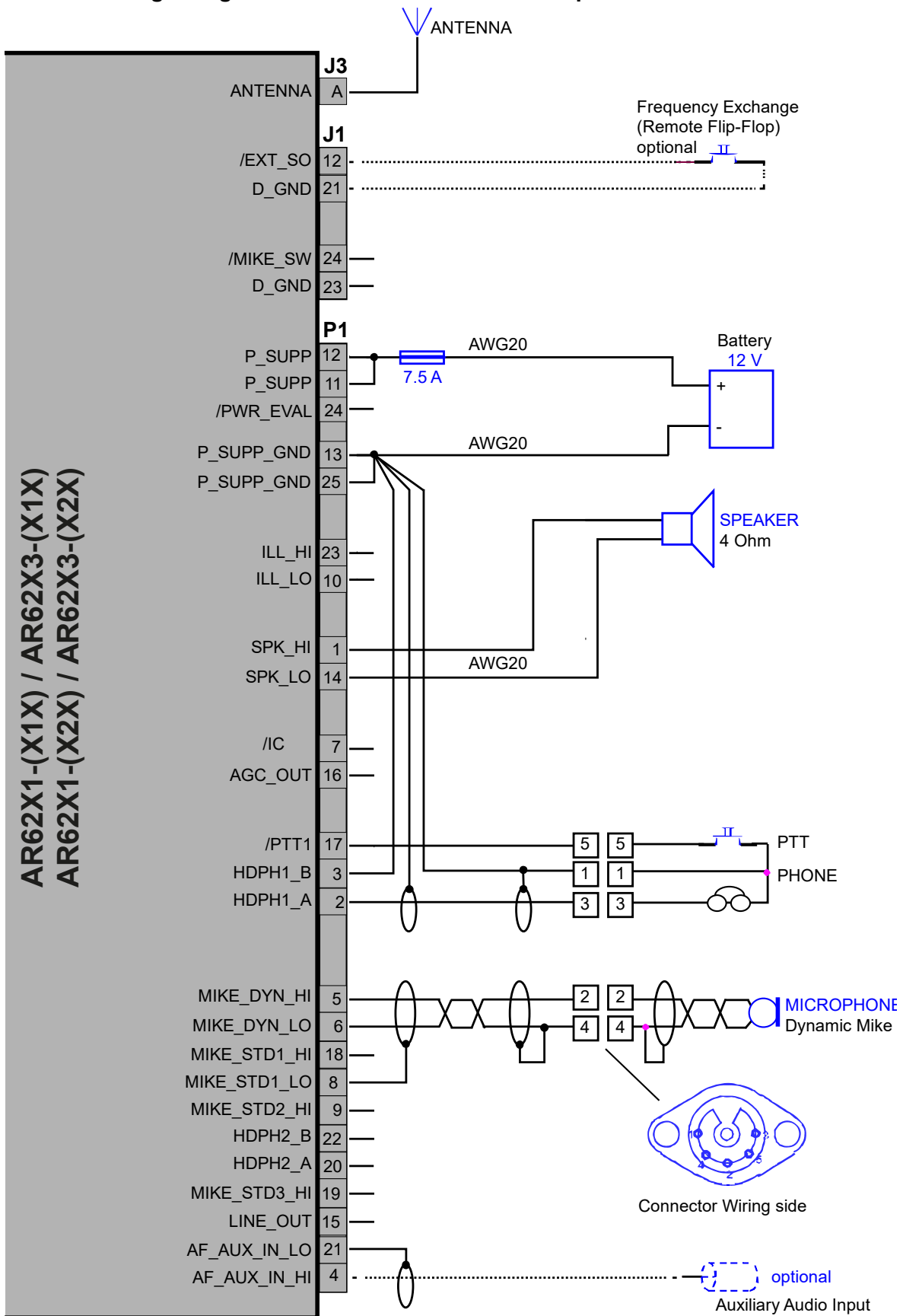

Figure 24: Wiring - Single Seat Glider 5-pol DIN Jack

Notice: Frequency exchange switch is optional.

2.9.3 Installation with RT62X1 and RCU62X1

2.9.3.1 Configuration - with RT62X1 and RCU62X1

- The RT62X1 with primary controller RCU62X1 can be used in all shown wirings.
- The RT62X1 with RCU62X1 replace an AR62X1 or AR62X3.

2.9.3.2 Wiring - with RT62X1 and RCU62X1

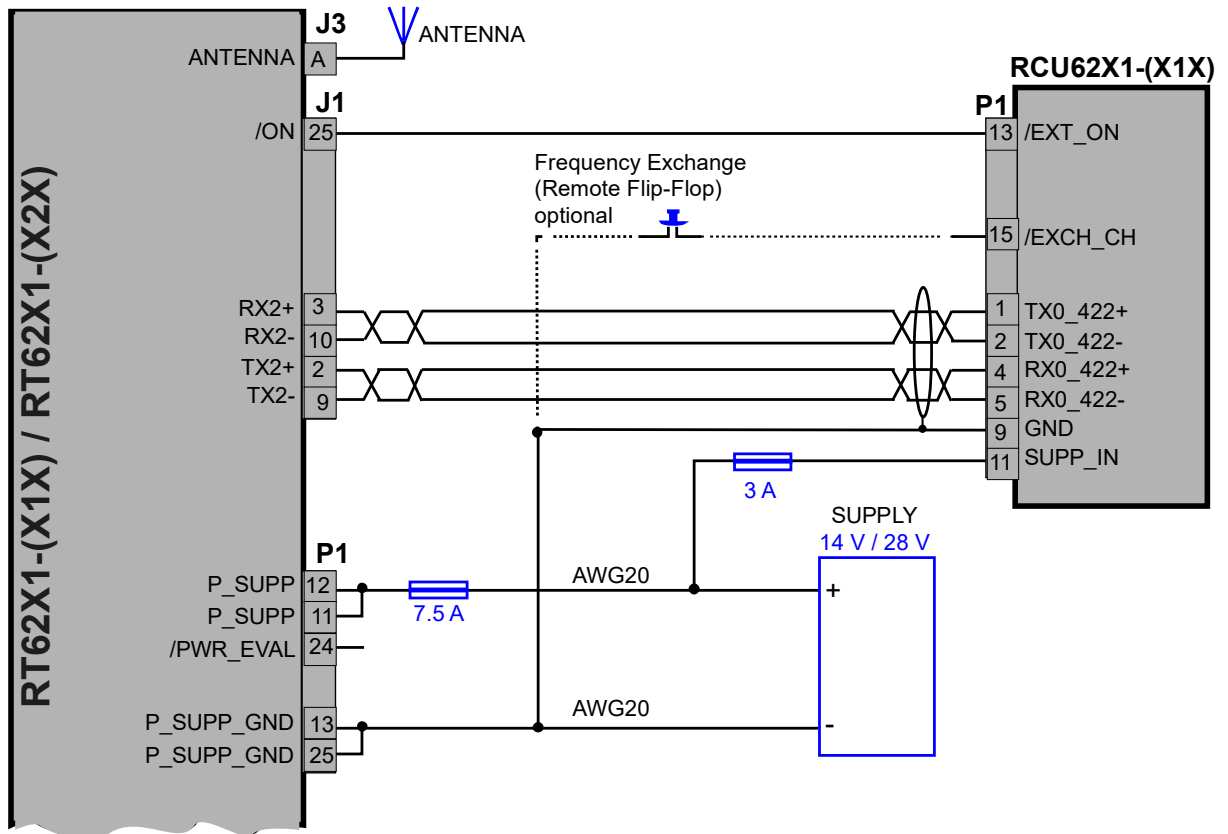

Figure 25: Wiring - Installation with RT62X1 and RCU62X1

2.9.4 Twin Seat with RT62X1 (Tandem-Installation)

2.9.4.1 Configuration - Twin Seat with RT62X1 (Tandem-Installation)

Sub-Menu	Function/Selection										
"SPKR VOLUME SOURCE"	BOTH										
"CONFIGURATION"	"SWAP MIKE IC" Disabled										
"IN/OUT CFG1" (/MIKE_SW open):	<table> <tr> <td>"MICROPHONE 1"</td> <td>STD1_MIKE</td> </tr> <tr> <td>"MICROPHONE 2"</td> <td>NONE</td> </tr> <tr> <td>"BOTH MIKES"</td> <td>Enabled</td> </tr> <tr> <td>"HEADPHONE 1"</td> <td>Enabled</td> </tr> <tr> <td>"SPEAKER"</td> <td>Disabled</td> </tr> </table> <ul style="list-style-type: none"> • If only headphone(s) are used, the speaker can be disabled by selecting NONE. • If only the speaker is used, HDPH 1 can be disabled. • The standard microphone is selected for both configurations. 	"MICROPHONE 1"	STD1_MIKE	"MICROPHONE 2"	NONE	"BOTH MIKES"	Enabled	"HEADPHONE 1"	Enabled	"SPEAKER"	Disabled
"MICROPHONE 1"	STD1_MIKE										
"MICROPHONE 2"	NONE										
"BOTH MIKES"	Enabled										
"HEADPHONE 1"	Enabled										
"SPEAKER"	Disabled										
"IN/OUT CFG2" (/MIKE_SW closed):	<table> <tr> <td>"MICROPHONE 1"</td> <td>STD1_MIKE</td> </tr> <tr> <td>"MICROPHONE 2"</td> <td>NONE</td> </tr> <tr> <td>"BOTH MIKES"</td> <td>Enabled</td> </tr> <tr> <td>"HEADPHONE 1"</td> <td>Enabled</td> </tr> <tr> <td>"SPEAKER"</td> <td>Enabled</td> </tr> </table>	"MICROPHONE 1"	STD1_MIKE	"MICROPHONE 2"	NONE	"BOTH MIKES"	Enabled	"HEADPHONE 1"	Enabled	"SPEAKER"	Enabled
"MICROPHONE 1"	STD1_MIKE										
"MICROPHONE 2"	NONE										
"BOTH MIKES"	Enabled										
"HEADPHONE 1"	Enabled										
"SPEAKER"	Enabled										
Remarks:	<ul style="list-style-type: none"> • If PTT is active then is the speaker muted. <p>The external switch (J1-24 /MIKE_SW) works as follows:</p> <ul style="list-style-type: none"> • Open: <ul style="list-style-type: none"> ○ Headset 1 for pilot selected. ○ Headset 2 for co-pilot selected. ○ The speaker is disabled. ○ Intercom with VOX is possible. • Closed: <ul style="list-style-type: none"> ○ Headset 1 selected (STD1). ○ Headset 2 disconnected (STD2). ○ Hand mike selected (STD3). ○ The speaker is enabled. ○ No intercom with VOX is possible. 										

2.9.4.2 Wiring - Twin Seat with RT62X1 (Tandem-Installation)

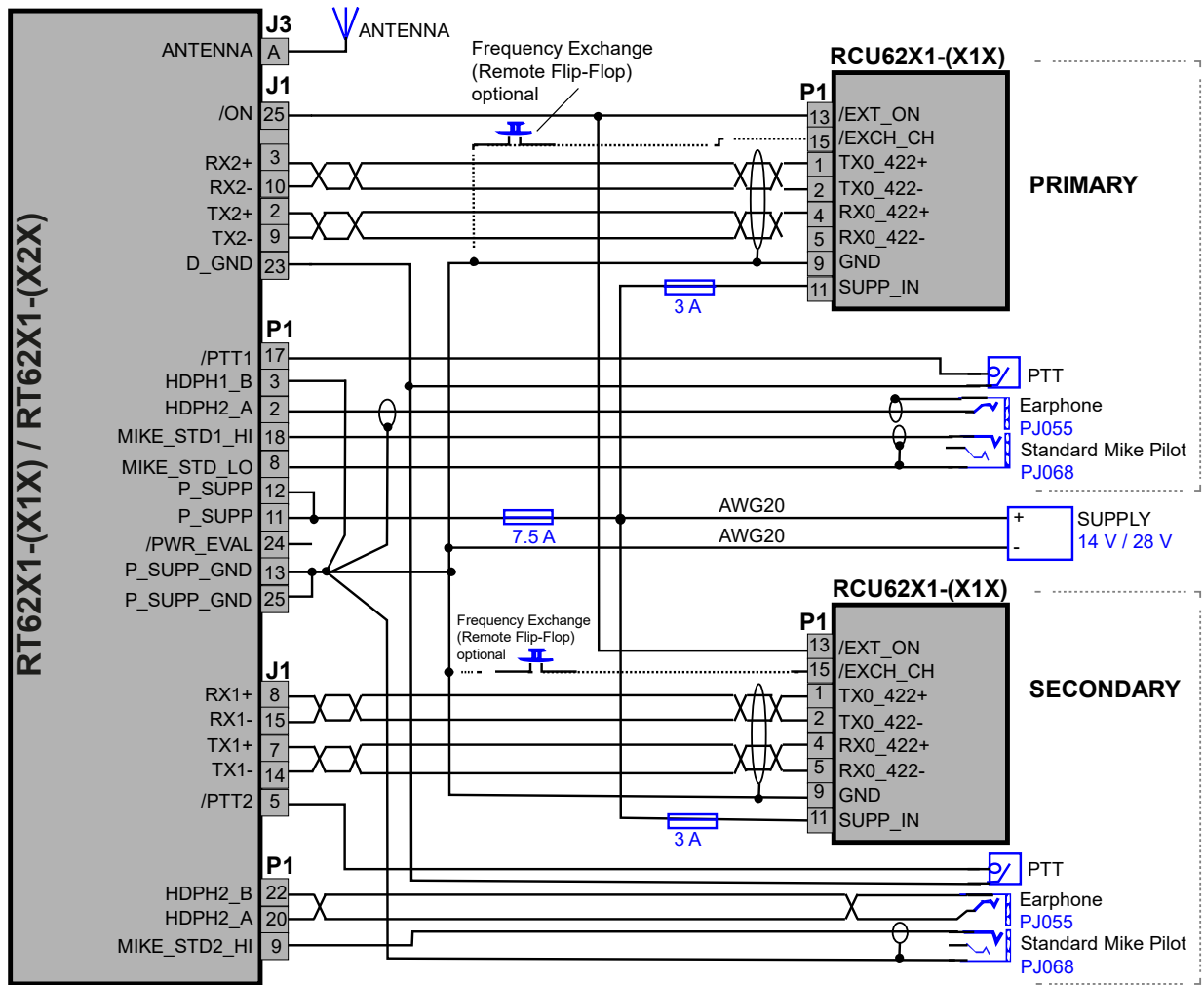

Figure 26: Wiring - Twin Seat with RT62X1 (Tandem-Installation)

Notice: Do the configuration setup only with the primary controller (RCU62X1).

2.9.5 Twin Seat Motor Glider

2.9.5.1 Configuration - Twin Seat Motor Glider

Sub-Menu	Function/Selection
"SPKR VOLUME SOURCE"	BOTH
"CONFIGURATION"	"SWAP MIKE IC" Disabled
"IN/OUT CFG1" (/MIKE_SW open):	"MICROPHONE 1" STD_1 MIKE "MICROPHONE 2" NONE "BOTH MIKES" Enabled "HEADPHONE 1" Enabled "SPEAKER" Disabled
"IN/OUT CFG2" (/MIKE_SW closed):	"MICROPHONE 1" NONE "MICROPHONE 2" DYN_MIKE "BOTH MIKES" Enabled "HEADPHONE 1" Enabled "SPEAKER" Enabled
Remarks:	<p>The external switch (J1-24 /MIKE_SW) works as follows:</p> <ul style="list-style-type: none"> • Open: <ul style="list-style-type: none"> ○ Standard microphone is selected. ○ The speaker is disabled. ○ Intercom with VOX is possible. • Closed: <ul style="list-style-type: none"> ○ Dynamic microphone is selected. ○ The speaker is enabled. ○ No Intercom with VOX is possible. • The speaker symbol is permanent shown on the display.

2.9.5.2 Wiring - Twin Seat Motor Glider

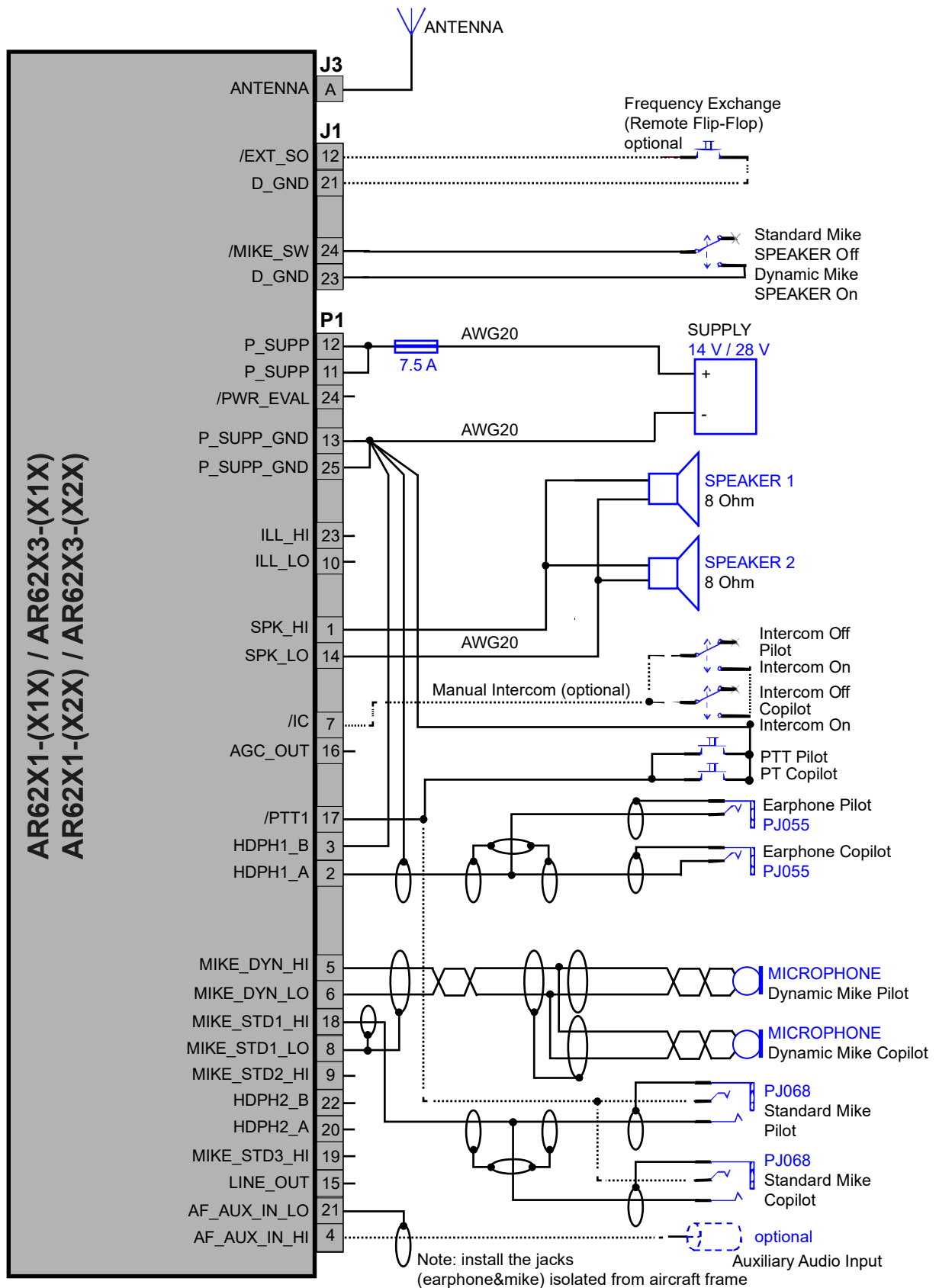

Figure 27: Wiring - Twin Seat Motor Glider

2.9.6 General Aviation (GA) Aircraft

2.9.6.1 Configuration - General Aviation Aircraft (with Standard Microphones)

Sub-Menu	Function/Selection
"SPKR VOLUME SOURCE"	BOTH
"CONFIGURATION"	"SWAP MIKE IC" Disabled
"IN/OUT CFG1" (/MIKE_SW open):	"MICROPHONE 1" STD1_MIKE "MICROPHONE 2" NONE "BOTH MIKES" Disabled "HEADPHONE 1" Enabled "SPEAKER" Disabled
"IN/OUT CFG2" (/MIKE_SW closed):	"MICROPHONE 1" STD1_MIKE "MICROPHONE 2" NONE "BOTH MIKES" Disabled "HEADPHONE 1" Enabled "SPEAKER" Enabled
Remarks:	<ul style="list-style-type: none"> The standard microphone input is selected regardless of the position of the external switch. <p>The external switch (J1-24 /MIKE_SW) works as follows:</p> <ul style="list-style-type: none"> Open: <ul style="list-style-type: none"> The speaker is disabled. Intercom with VOX is possible. Closed: <ul style="list-style-type: none"> The speaker is enabled. No intercom with VOX is possible. The speaker symbol is permanent shown on the display.

2.9.6.2 Wiring - General Aviation Aircraft (with Standard Microphones)

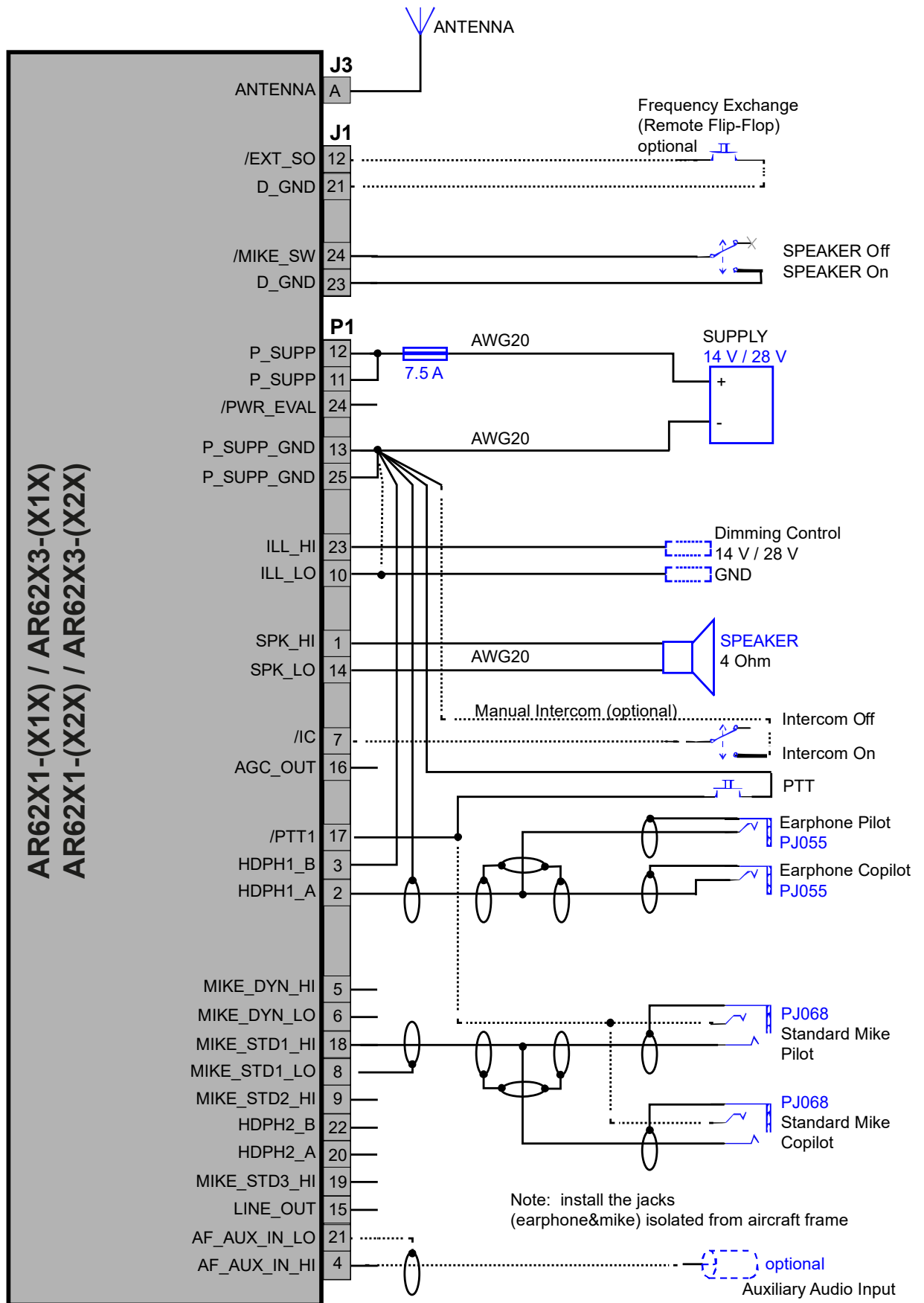

Figure 28: Wiring - General Aviation Aircraft (with Standard Hand Mikes, Earphones and Speaker)

2.9.7 Individual Dual Headset Installation (two IC Circuits)

2.9.7.1 Configuration - Individual Dual Headset Installation (two IC Circuits)

Sub-Menu	Function/Selection
"SPKR VOLUME SOURCE"	BOTH
"CONFIGURATION"	"SWAP MIKE IC" Disabled
"IN/OUT CFG1" (/MIKE_SW open):	"MICROPHONE 1" STD1_MIKE "MICROPHONE 2" STD2_MIKE "BOTH MIKES" : Disabled "HEADPHONE 1" Enabled "HEADPHONE 2" Enabled "SPEAKER" Disabled The standard microphone is selected for both configurations.
"IN/OUT CFG2" (/MIKE_SW closed):	"MICROPHONE 1" STD1_MIKE "MICROPHONE 2" STD3_MIKE "BOTH MIKES" Enabled "HEADPHONE 1" Disabled "SPEAKER" Enabled
Remarks:	<p>The external switch (connected to pin J1-24 /MIKE_SW) works as follows:</p> <ul style="list-style-type: none"> • Open: <ul style="list-style-type: none"> ○ Headset 1 for pilot is selected (STD1). ○ Headset 2 for co-pilot is selected (STD2). ○ The speaker is disabled. ○ Intercom with VOX is possible. • Closed: <ul style="list-style-type: none"> ○ Headset 1 is selected (STD1). ○ Headset 2 is disconnected (STD2). ○ The hand mike is selected (STD3). ○ The speaker is enabled. ○ No intercom with VOX is possible.

2.9.7.2 Wiring - Individual Dual Headset Installation (two IC Circuits)

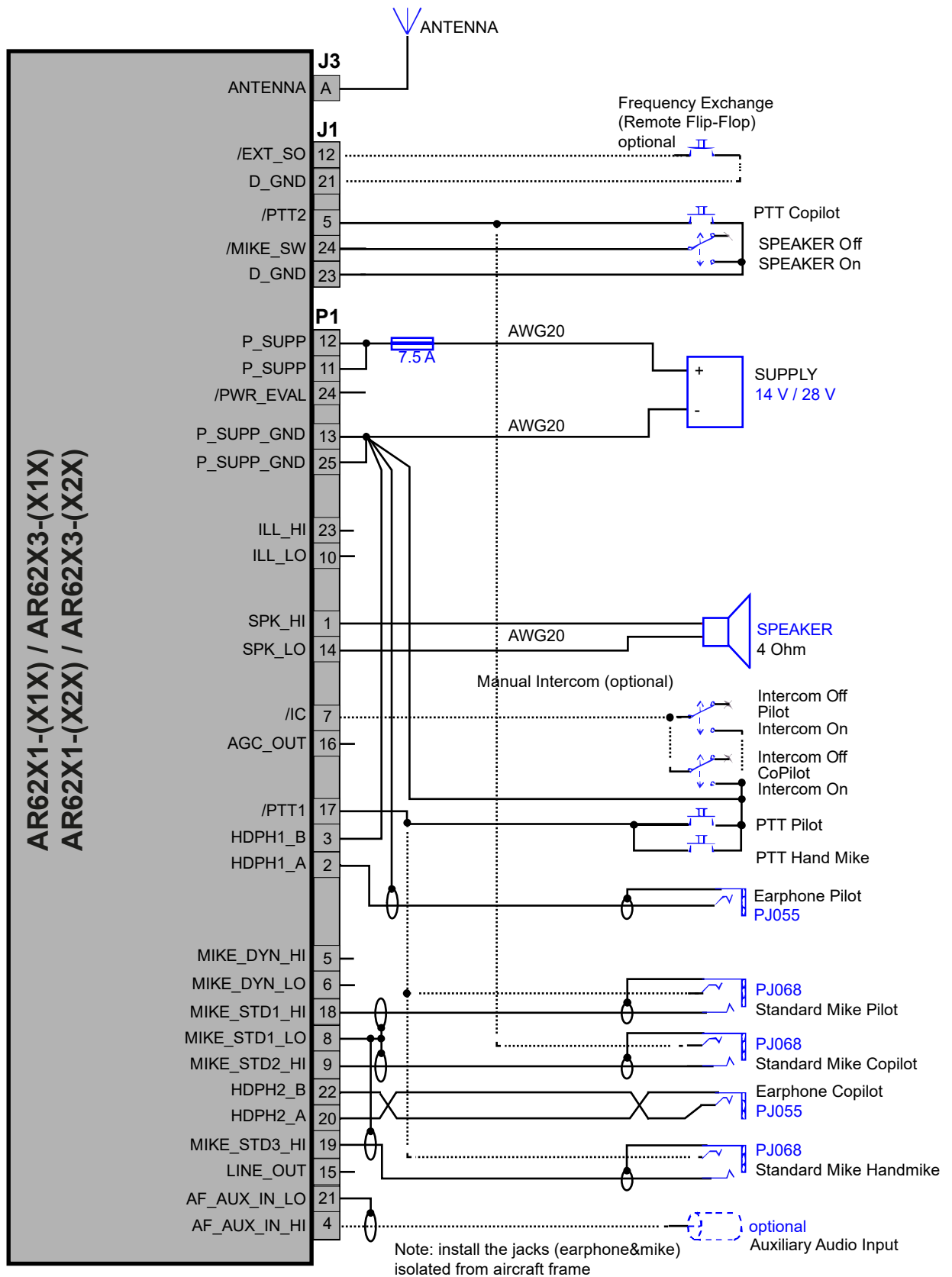

Figure 29: Wiring - Individual Dual Headset Installation (two IC Circuits)

2.9.8 Twin Seat with AR62XX (Tandem-Installation)

2.9.8.1 Configuration - Twin Seat with AR62XX (Tandem-Installation)

Sub-Menu	Function/Selection										
"SPKR VOLUME SOURCE"	BOTH										
"CONFIGURATION"	"SWAP MIKE IC" Disabled										
"IN/OUT CFG1" (/MIKE_SW open):	<table> <tr> <td>"MICROPHONE 1"</td> <td>STD1_MIKE</td> </tr> <tr> <td>"MICROPHONE 2"</td> <td>NONE</td> </tr> <tr> <td>"BOTH MIKES"</td> <td>Enabled</td> </tr> <tr> <td>"HEADPHONE 1"</td> <td>Enabled</td> </tr> <tr> <td>"SPEAKER"</td> <td>Disabled</td> </tr> </table> <ul style="list-style-type: none"> • If only headphone(s) are used, The speaker can be disabled by selecting NONE. • If only the speaker is used, HDPH 1 can be disabled. • The standard microphone is selected for both configurations. 	"MICROPHONE 1"	STD1_MIKE	"MICROPHONE 2"	NONE	"BOTH MIKES"	Enabled	"HEADPHONE 1"	Enabled	"SPEAKER"	Disabled
"MICROPHONE 1"	STD1_MIKE										
"MICROPHONE 2"	NONE										
"BOTH MIKES"	Enabled										
"HEADPHONE 1"	Enabled										
"SPEAKER"	Disabled										
"IN/OUT CFG2" (/MIKE_SW closed):	<table> <tr> <td>"MICROPHONE 1"</td> <td>STD1_MIKE</td> </tr> <tr> <td>"MICROPHONE 2"</td> <td>NONE</td> </tr> <tr> <td>"BOTH MIKES"</td> <td>Enabled</td> </tr> <tr> <td>"HEADPHONE 1"</td> <td>Enabled</td> </tr> <tr> <td>"SPEAKER"</td> <td>Enabled</td> </tr> </table>	"MICROPHONE 1"	STD1_MIKE	"MICROPHONE 2"	NONE	"BOTH MIKES"	Enabled	"HEADPHONE 1"	Enabled	"SPEAKER"	Enabled
"MICROPHONE 1"	STD1_MIKE										
"MICROPHONE 2"	NONE										
"BOTH MIKES"	Enabled										
"HEADPHONE 1"	Enabled										
"SPEAKER"	Enabled										
Remarks:	<ul style="list-style-type: none"> • If PTT is active then is the speaker muted. <p>The external switch (J1-24 /MIKE_SW) works as follows:</p> <ul style="list-style-type: none"> • Open: <ul style="list-style-type: none"> ○ Headset 1 for pilot selected. ○ Headset 2 for co-pilot selected. ○ The speaker is disabled. ○ Intercom with VOX is possible. • Closed: <ul style="list-style-type: none"> ○ Headset 1 selected (STD1). ○ Headset 2 disconnected (STD2). ○ Hand mike selected (STD3). ○ The speaker is enabled. ○ No intercom with VOX is possible. 										

2.9.8.2 Wiring - Twin Seat with AR62XX (Tandem-Installation)

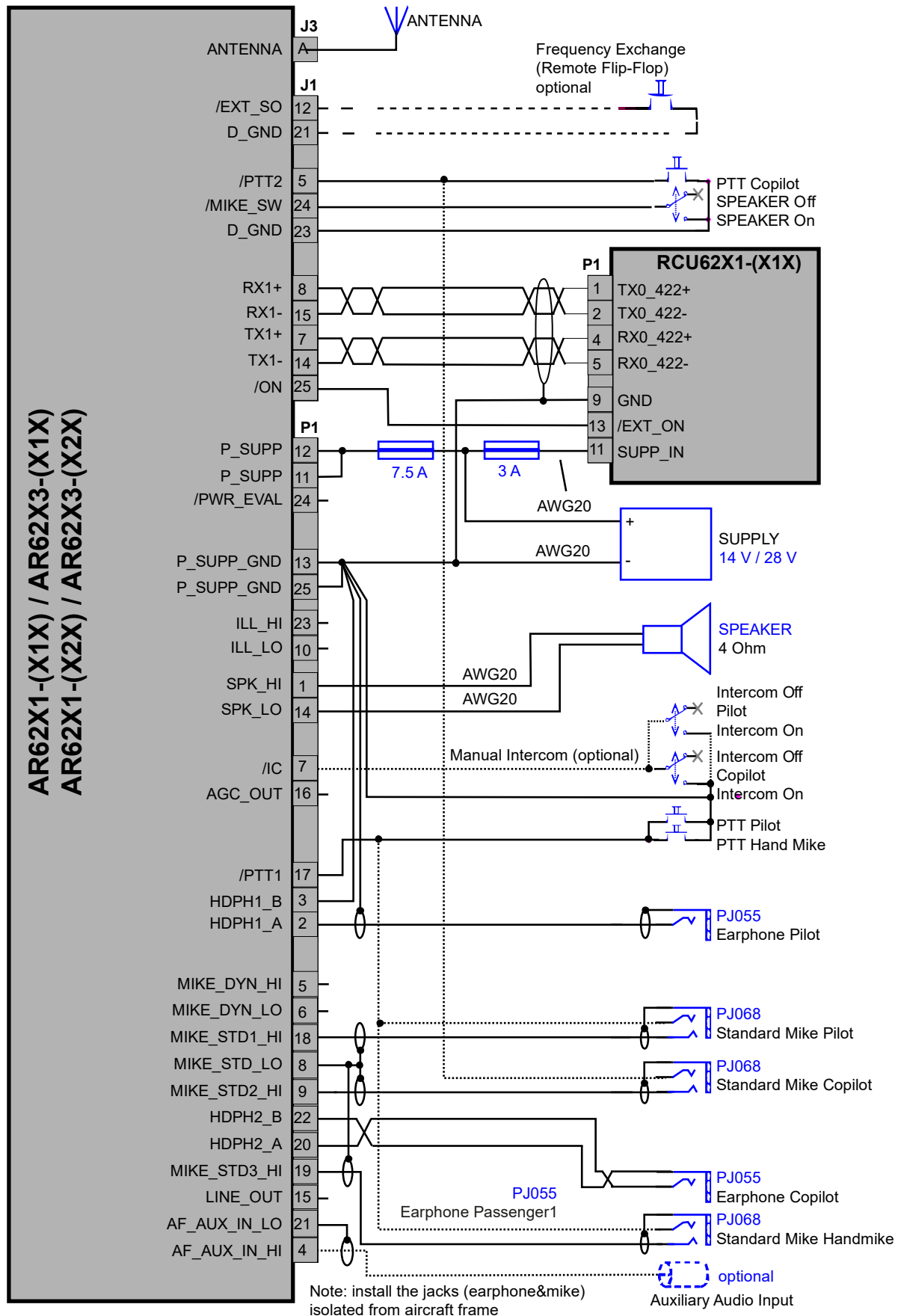

Figure 30: Wiring - Twin Seat with AR62XX (Tandem-Installation)

2.9.9 Four Seat Installation (no Tandem)

2.9.9.1 Configuration - Four Seat Installation (no Tandem)

Sub-Menu	Function/Selection												
"SPKR VOLUME SOURCE	BOTH												
"CONFIGURATION"	"SWAP MIKE IC" Disabled												
"IN/OUT CFG1" (/MIKE_SW open):	<table border="0"> <tr> <td>"MICROPHONE 1"</td> <td>STD1_MIKE</td> </tr> <tr> <td>"MICROPHONE 2"</td> <td>STD3_MIKE</td> </tr> <tr> <td>"BOTH MIKES"</td> <td>Enabled</td> </tr> <tr> <td>"HEADPHONE 1"</td> <td>Disabled</td> </tr> <tr> <td>"SPEAKER"</td> <td>Enabled</td> </tr> </table> <ul style="list-style-type: none"> • If only headphone(s) are used, the speaker can be disabled by selecting NONE. • If only the speaker is used, HDPH 1 can be disabled. • The standard microphone is selected for both configurations. 	"MICROPHONE 1"	STD1_MIKE	"MICROPHONE 2"	STD3_MIKE	"BOTH MIKES"	Enabled	"HEADPHONE 1"	Disabled	"SPEAKER"	Enabled		
"MICROPHONE 1"	STD1_MIKE												
"MICROPHONE 2"	STD3_MIKE												
"BOTH MIKES"	Enabled												
"HEADPHONE 1"	Disabled												
"SPEAKER"	Enabled												
"IN/OUT CFG2" (/MIKE_SW closed):	<table border="0"> <tr> <td>"MICROPHONE 1"</td> <td>STD1_MIKE</td> </tr> <tr> <td>"MICROPHONE 2"</td> <td>STD2_MIKE</td> </tr> <tr> <td>"BOTH MIKES"</td> <td>Disabled</td> </tr> <tr> <td>"HEADPHONE 1"</td> <td>Enabled</td> </tr> <tr> <td>"HEADPHONE 2"</td> <td>Enabled</td> </tr> <tr> <td>"SPEAKER"</td> <td>Disabled</td> </tr> </table>	"MICROPHONE 1"	STD1_MIKE	"MICROPHONE 2"	STD2_MIKE	"BOTH MIKES"	Disabled	"HEADPHONE 1"	Enabled	"HEADPHONE 2"	Enabled	"SPEAKER"	Disabled
"MICROPHONE 1"	STD1_MIKE												
"MICROPHONE 2"	STD2_MIKE												
"BOTH MIKES"	Disabled												
"HEADPHONE 1"	Enabled												
"HEADPHONE 2"	Enabled												
"SPEAKER"	Disabled												
Remarks	<ul style="list-style-type: none"> • If PTT is active then is the speaker muted. <p>The external switch (J1-24 /MIKE_SW) works as follows:</p> <ul style="list-style-type: none"> • Open: <ul style="list-style-type: none"> ○ Headset 1 and 2 for pilot and co-pilot selected. ○ Headset 3 and 4 for passengers selected. ○ The speaker is enabled. ○ Intercom with VOX is not possible. • Closed: <ul style="list-style-type: none"> ○ Headset 1 and 2 for pilot and co-pilot selected. ○ Headset 3 and 4 disconnected. ○ The hand mike selected (STD3). ○ The speaker is disabled. ○ Intercom with VOX is possible. 												

2.9.9.2 Wiring - Four Seat Installation (no Tandem)

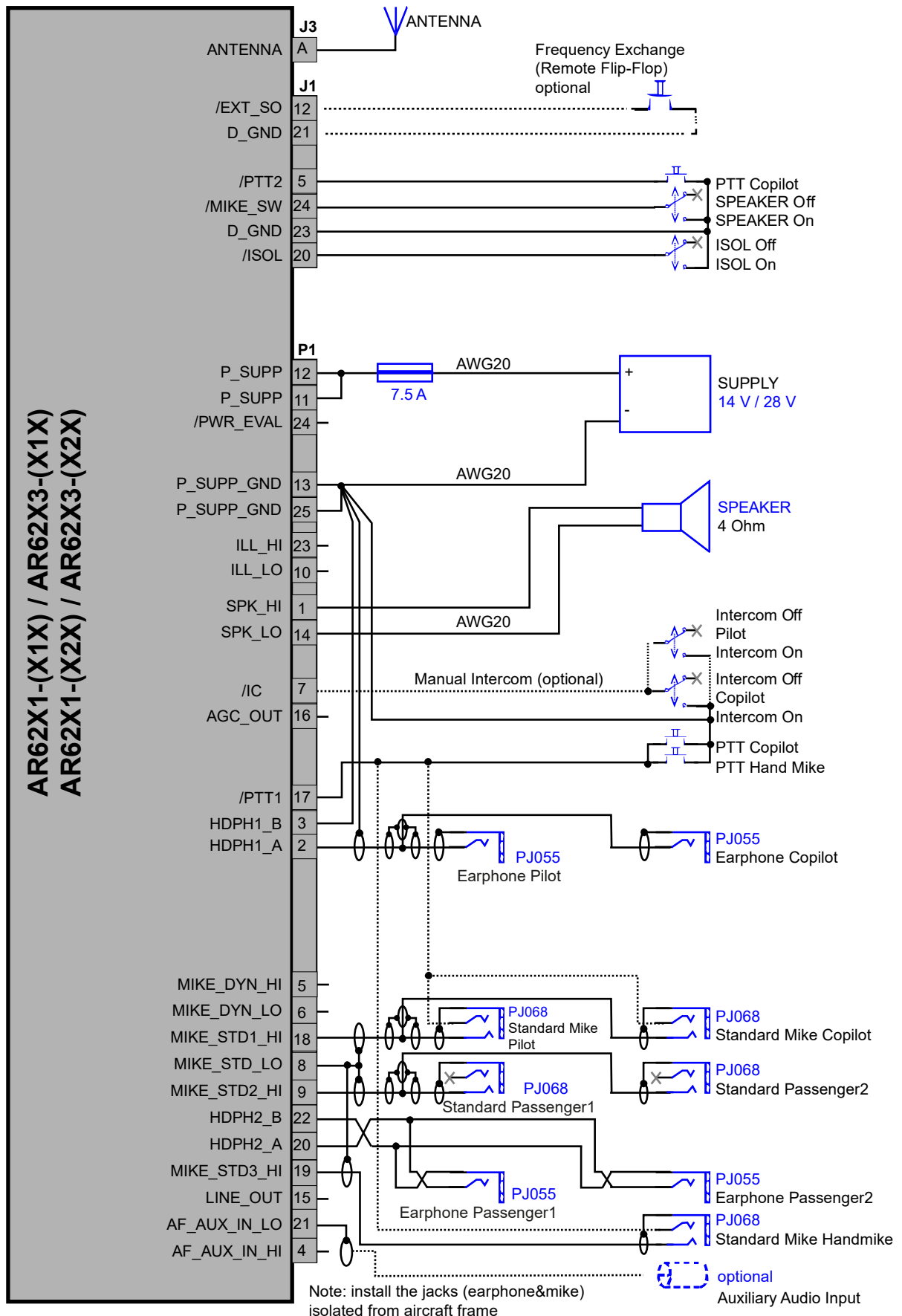

Figure 31: Wiring - Four Seat Installation (no Tandem)

2.9.10 Installation in Aircraft with Intercom System

2.9.10.1 Configuration - Aircraft with Intercom System

Sub-Menu	Function/Selection	
"SPKR VOLUME SOURCE"	BOTH	
"CONFIGURATION"	"SWAP MIKE IC"	Disabled
"IN/OUT CFG1":	"MICROPHONE 1"	STD1_MIKE
	"MICROPHONE 2"	NONE
	"BOTH MIKES"	Enabled
	"HEADPHONE 1"	Enabled
	"SPEAKER"	Disabled
"IN/OUT FG2"	"MICROPHONE 1"	STD1_MIKE
	"MICROPHONE 2"	NONE
	"BOTH MIKES"	Enabled
	"HEADPHONE 1"	Enabled
	"SPEAKER"	Enabled
Remarks:	Use the same configuration for balanced and unbalanced wiring.	

2.9.10.2 Wiring - Aircraft with Intercom System (Unbalanced)

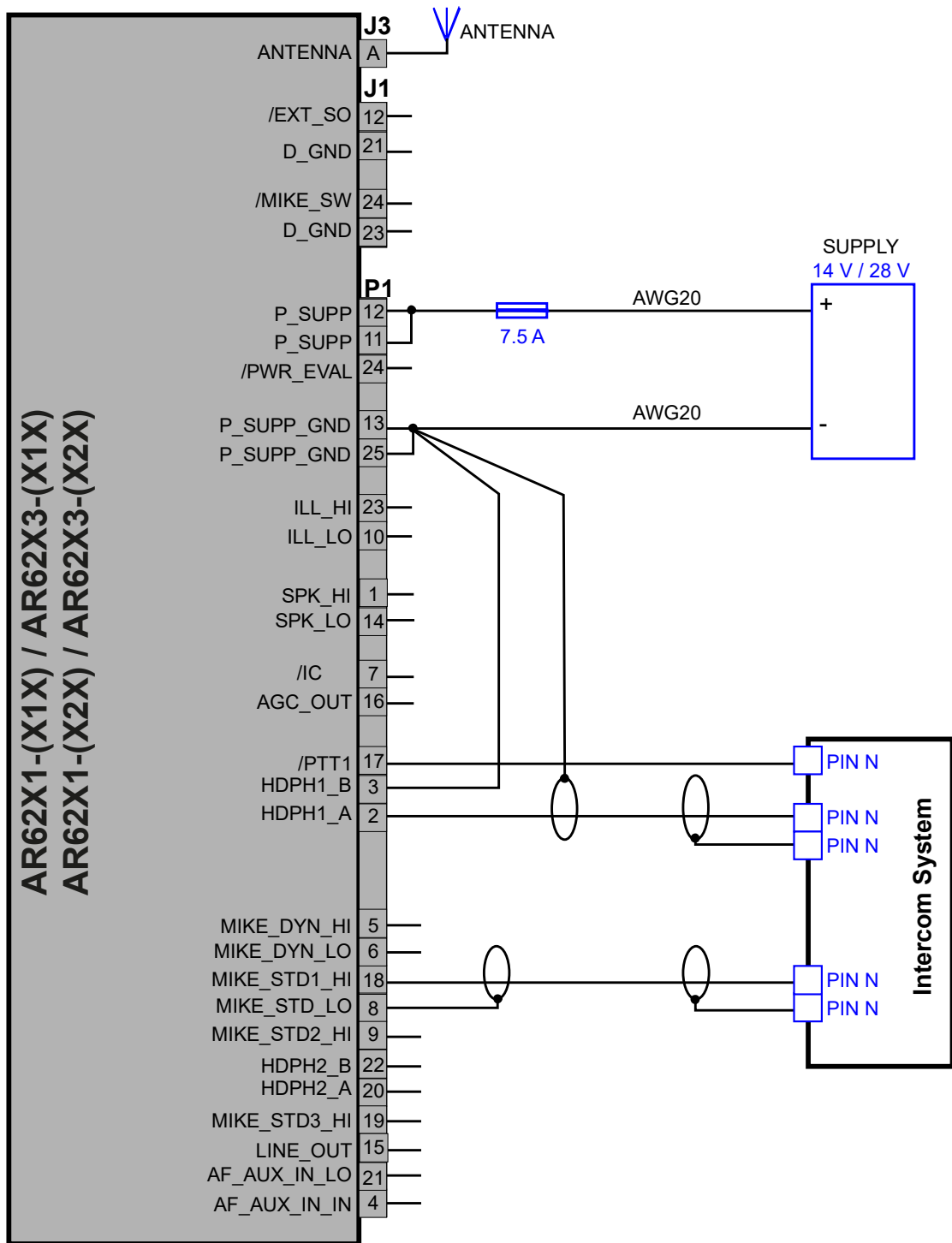

Figure 32: Wiring - Aircraft with Intercom System (Unbalanced)

2.9.10.3 Wiring - Aircraft with Intercom System (Balanced)

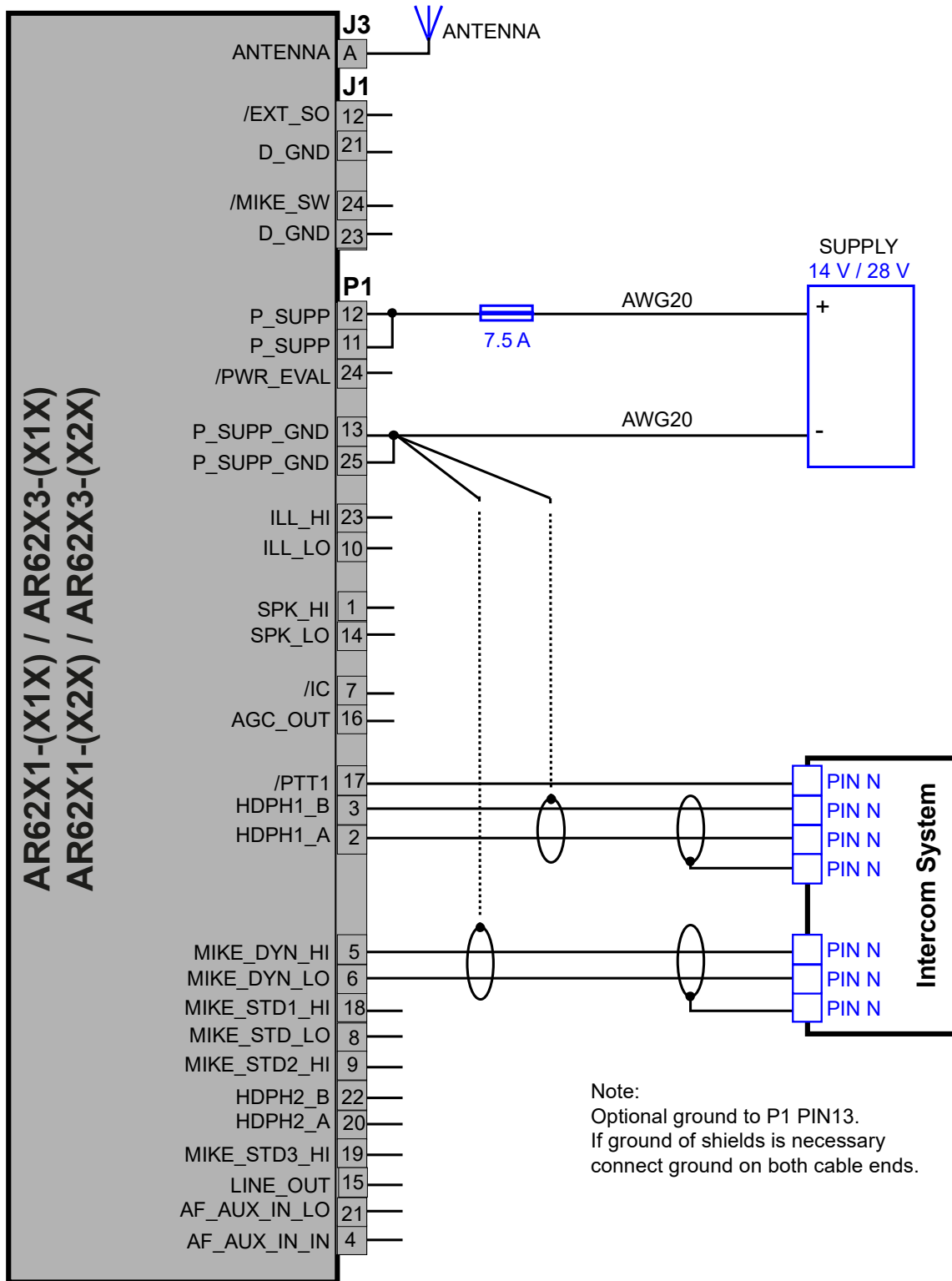

Figure 33: Wiring - Aircraft with Intercom System (Balanced)

2.9.11 Recommendation for the Installation of two Transceivers in one Aircraft

This information gives guidance to installers for installations with two AR/RT series VHF air band communication radios on-board of the same aircraft.

In order to minimize the risk of cross talk issues, a special care has to be applied during the installation of the subsequent antennas on the fuselage, see "Antenna Installation" page 66.

Becker recommends to configure the muting functionality in the AR/RT series and to do the related wiring as described here.

2.9.11.1 Configuration - Two Transceivers in one Aircraft

To use the AR/RT series in a dual com context, a muting function can be set. Obey the procedure that follows:

- The radio has two input and output configurations which are changeable by the installer in the configuration setup menu.
- The selection of configuration 1 or configuration 2 is done by an external input called external mike switch.
 - To do this it is necessary to adapt a cross link wire from the "Push-To-Talk" input of the first transceiver to the "External Mike Switch" of the second transceiver.

External Mike Switch (/MIKE_SW)

Pin No.	Pin Name	Direction	Function
J1-24	/MIKE_SW	IN	Configuration selector CFG1 and CFG2. ACTIVE state - closed contact to GND

- The external mike switch is used for selection between the audio in/out configurations CFG1 and CFG2.
- When /MIKE_SW is active then configuration CFG2 is in use.
- When /MIKE_SW is inactive then CFG1 is in use.
- The configurations CFG1 and CFG2 contain parameters which are set in the configuration setup pages (for details see "Configuration" page 75).
- You can change the configurations during the flight in the configuration setup.

Push-To-Talk (/PTT)

Pin No.	Pin Name	I/O	Function
P1-17	/PTT1	IN	Push-To-Talk key input 1 ACTIVE state - closed contact to GND
J1-5	/PTT2	IN	Push-To-Talk key input 2 ACTIVE state - closed contact to GND

- There are two Push-To-Talk inputs available /PTT1 and /PTT2 (e.g. one for the pilot and one for the co-pilot).
- Each input has an internal pull up.
- While the input is connected to ground a current of < 1 mA flows.
 - The transceiver enters transmit operation, if one or both inputs are connected to ground.
- According to microphone(s) configuration, the signal from particular inputs can or cannot modulate transmissions.

The IN/OUT CFG1 can be set from the user:

Display Contents	Description
<div style="border: 1px solid black; padding: 5px; margin-bottom: 10px;"> <p>IN/OUT CFG 1</p> <p>MICROPHONE 1 <input type="text" value=""/></p> <ul style="list-style-type: none"> <input type="radio"/> STD 1 MIKE <input type="radio"/> STD 2 MIKE <input type="radio"/> STD 3 MIKE <input checked="" type="radio"/> DYN MIKE <input type="radio"/> NONE </div> <div style="border: 1px dashed black; padding: 5px;"> <p>MICROPHONE 2</p> <ul style="list-style-type: none"> <input type="radio"/> STD 1 MIKE <input type="radio"/> STD 2 MIKE <input type="radio"/> STD 3 MIKE <input type="radio"/> DYN MIKE <input checked="" type="radio"/> NONE <p>MIC ACTIVATION</p> <ul style="list-style-type: none"> <input checked="" type="checkbox"/> BOTH MIKES <p>OUTPUTS</p> <ul style="list-style-type: none"> <input checked="" type="checkbox"/> HEADPHONE 1 <input type="checkbox"/> HEADPHONE 2 <input checked="" type="radio"/> SPEAKER <input type="radio"/> NONE </div>	<p>"IN/OUT CFG1":</p> <p>Notice: The menu is available on the primary controller.</p> <p>Notice: "IN/OUT CFG1" is shown only when MIKE_SW input has active state (J1-24). When MIKE_SW is connected both configurations CFG1 and CFG2 must be configured.</p> <ul style="list-style-type: none"> • On this page you can configure the microphone inputs and headphone outputs for configuration CFG1. • Select the option with the rotary encoder. <p>"MICROPHONE 1" (set only one of the options):</p> <p>STD1 MIKE:</p> <ul style="list-style-type: none"> • Standard microphone input 1 is selected (P1-18/ P1-8). <p>STD2 MIKE:</p> <ul style="list-style-type: none"> • Standard microphone input 2 is selected (P1-9/ P1-8). <p>STD3 MIKE:</p> <ul style="list-style-type: none"> • Standard microphone input 3 is selected (P1-19/ P1-8). <p>DYN MIKE:</p> <ul style="list-style-type: none"> • Dynamic microphone input is selected (P1-6/ P1-5). <p>NONE:</p> <ul style="list-style-type: none"> • No microphone is used in microphone path 1. <p>"MICROPHONE 2" (set only one of the options):</p> <p>STD1 MIKE:</p> <ul style="list-style-type: none"> • Standard microphone input 1 is selected (P1-18/ P1-8). <p>STD2 MIKE:</p> <ul style="list-style-type: none"> • Standard microphone input 2 is selected (P1-9/ P1-8). <p>STD3 MIKE:</p> <ul style="list-style-type: none"> • Standard microphone input 3 is selected (P1-19/ P1-8). <p>DYN MIKE:</p> <ul style="list-style-type: none"> • Dynamic microphone input is selected (P1-6/ P1-5). <p>NONE:</p> <ul style="list-style-type: none"> • No microphone is used in microphone path 2. <p>"MIC ACTIVATION"</p> <p>BOTH MIKES ENABLED:</p> <ul style="list-style-type: none"> • Input /PTT1 starts transmission from microphone path 1 and 2 (P1-17). • Input /PTT2 starts transmission from microphone path 2 and path 1 (J1-5). • Input /IC starts intercom from microphone path 1 and 2 (P1-7). <p>BOTH MIKES DISABLED:</p> <ul style="list-style-type: none"> • Input /PTT1 starts transmission only from microphone path 1 (P1-17). • Input /PTT2 starts transmission only from microphone path 2 (J1-5). • Input /IC starts intercom only from microphone path 1 (P1-7). <p>"OUTPUTS"</p> <p>HDPH 1 ENABLED:</p> <ul style="list-style-type: none"> • Audio is available on headphone 1 output (P1-2/P1-3). <p>HDPH 1 DISABLED:</p> <ul style="list-style-type: none"> • No audio is available on headphone 1 output. <p>HDPH 2 ENABLED:</p> <ul style="list-style-type: none"> • Audio is available on headphone 2 output (P1-20/P1-22), speaker is not available.

Display Contents	Description
	<p>HDPH 2 DISABLED:</p> <ul style="list-style-type: none"> No audio is available on headphone 2 output, speaker is not available. <p>SPEAKER ENABLED:</p> <ul style="list-style-type: none"> Audio is available on speaker (P1-1/P1-14), headphone 2 is not available. <p>NONE:</p> <ul style="list-style-type: none"> No audio on headphone 2 output or speaker output.

NOTICE The IN/OUT CFG2 contains the muting in the way that the "OUTPUTS" are selected to NONE.

The IN/OUT CFG2 can be set from the user:

Display Contents	Description
<div style="border: 1px solid black; padding: 5px;"> <p>IN/OUT CFG 2</p> <p>MICROPHONE 1</p> <ul style="list-style-type: none"> <input type="radio"/> STD 1 MIKE <input type="radio"/> STD 2 MIKE <input type="radio"/> STD 3 MIKE <input checked="" type="radio"/> DYN MIKE <input type="radio"/> NONE </div> <div style="border: 1px dashed black; padding: 5px; margin-top: 5px;"> <p>MICROPHONE 2</p> <ul style="list-style-type: none"> <input type="radio"/> STD 1 MIKE <input type="radio"/> STD 2 MIKE <input type="radio"/> STD 3 MIKE <input type="radio"/> DYN MIKE <input checked="" type="radio"/> NONE <p>MIC ACTIVATION</p> <p><input checked="" type="checkbox"/> BOTH MIKES</p> <p>OUTPUTS</p> <p><input type="checkbox"/> HEADPHONE 1</p> <ul style="list-style-type: none"> <input type="radio"/> HEADPHONE 2 <input type="radio"/> SPEAKER <input checked="" type="radio"/> NONE </div>	<p>"IN/OUT CFG2":</p> <p>Notice: The menu is available on the primary controller.</p> <p>Notice: "IN/OUT CFG2" is shown only when the MIKE_SW input has active state (J1-24). When MIKE_SW is connected both configurations CFG1 and CFG2 must be configured.</p> <ul style="list-style-type: none"> On this page you can configure the microphone inputs and headphone outputs for configuration CFG2. Select the option with the rotary encoder. <p>"MICROPHONE 1" (set only one of the options):</p> <p>STD1 MIKE:</p> <ul style="list-style-type: none"> Standard microphone input 1 is selected (P1-18/ P1-8). <p>STD2 MIKE:</p> <ul style="list-style-type: none"> Standard microphone input 2 is selected (P1-9/ P1-8). <p>STD3 MIKE:</p> <ul style="list-style-type: none"> Standard microphone input 3 is selected (P1-19/ P1-8). <p>DYN MIKE:</p> <ul style="list-style-type: none"> Dynamic microphone input is selected (P1-6/ P1-5). <p>NONE:</p> <ul style="list-style-type: none"> No microphone is used in microphone path 1. <p>"MICROPHONE 2" (set only one of the options):</p> <p>STD1 MIKE:</p> <ul style="list-style-type: none"> Standard microphone input 1 is selected (P1-18/ P1-8). <p>STD2 MIKE:</p> <ul style="list-style-type: none"> Standard microphone input 2 is selected (P1-9/ P1-8). <p>STD3 MIKE:</p> <ul style="list-style-type: none"> Standard microphone input 3 is selected (P1-19/ P1-8). <p>DYN MIKE:</p> <ul style="list-style-type: none"> Dynamic microphone input is selected (P1-6/ P1-5). <p>NONE:</p> <ul style="list-style-type: none"> No microphone is used in microphone path 2. <p>"MIC ACTIVATION"</p> <p>BOTH MIKES ENABLED:</p> <ul style="list-style-type: none"> Input /PTT1 starts transmission from microphone path 1 and 2 (P1-17). Input /PTT2 starts transmission from microphone path 2 and 1 (J1-5). Input /IC starts intercom from microphone path 1 and 2 (P1-7).

Display Contents	Description
	<p>BOTH MIKES DISABLED:</p> <ul style="list-style-type: none"> • Input /PTT1 starts transmission only from microphone path 1 (P1-17). • Input /PTT2 starts transmission only from microphone path 2 (Pin J1-5). • Input /IC starts intercom only from microphone path 1 (P1-7). <p>"OUTPUTS"</p> <p>HDPH 1 ENABLED:</p> <ul style="list-style-type: none"> • Audio is available on headphone 1 output (P1-2/P1-3). <p>HDPH 1 DISABLED:</p> <ul style="list-style-type: none"> • No audio is available on headphone 1 output. <p>HDPH 2 ENABLED:</p> <ul style="list-style-type: none"> • Audio is available on headphone 2 output (P1-20/P1-22), speaker is not available. <p>HDPH 2 DISABLED:</p> <ul style="list-style-type: none"> • No audio is available on headphone 2 output, speaker is not available. <p>SPEAKER ENABLED:</p> <ul style="list-style-type: none"> • Audio is available on speaker (P1-1/P1-14), headphone 2 is not available. <p>NONE:</p> <ul style="list-style-type: none"> • No audio on headphone 2 output or speaker output.

That means during transmission of a radio, the other radio with this crosslink feature will have all outputs muted (no audio signal at all).

NOTICE

Voice transmission is still available but with no sidetone on the audio outputs.

2.9.12 Cable Harness

2.9.12.1 Configuration - 1K065 for General Aviation

The IN/OUT CFG1 can be set from the user:

Display Contents	Description
<div style="border: 1px solid black; padding: 5px; margin-bottom: 10px;"> <p>IN/OUT CFG 1</p> <p>MICROPHONE 1 <input type="text" value=""/></p> <ul style="list-style-type: none"> ● STD 1 MIKE ○ STD 2 MIKE ○ STD 3 MIKE ○ DYN MIKE ○ NONE </div> <div style="border: 1px dashed black; padding: 5px;"> <p>MICROPHONE 2</p> <ul style="list-style-type: none"> ○ STD 1 MIKE ● STD 2 MIKE ○ STD 3 MIKE ○ DYN MIKE ○ NONE <p>MIC ACTIVATION</p> <ul style="list-style-type: none"> <input checked="" type="checkbox"/> BOTH MIKES OUTPUTS <input checked="" type="checkbox"/> HEADPHONE 1 ○ HEADPHONE 2 ○ SPEAKER ● NONE </div>	<p>"IN/OUT CFG1":</p> <p>Notice: The menu is available on the primary controller.</p> <p>Notice: "IN/OUT CFG1" is shown only when MIKE_SW input has active state (J1-24). When MIKE_SW is connected both configurations_CFG1 and CFG2 must be configured.</p> <ul style="list-style-type: none"> ● On this page you can configure the microphone inputs and headphone outputs for configuration CFG1. ● Select the option with the rotary encoder. <p>"MICROPHONE 1" (set only one of the options):</p> <p>STD1 MIKE:</p> <ul style="list-style-type: none"> ● Standard microphone input 1 is selected (P1-18/ P1-8). <p>STD2 MIKE:</p> <ul style="list-style-type: none"> ● Standard microphone input 2 is selected (P1-9/ P1-8). <p>STD3 MIKE:</p> <ul style="list-style-type: none"> ● Standard microphone input 3 is selected (P1-19/ P1-8). <p>DYN MIKE:</p> <ul style="list-style-type: none"> ● Dynamic microphone input is selected (P1-6/ P1-5). <p>NONE:</p> <ul style="list-style-type: none"> ● No microphone is used in microphone path 1. <p>"MICROPHONE 2" (set only one of the options):</p> <p>STD1 MIKE:</p> <ul style="list-style-type: none"> ● Standard microphone input 1 is selected (P1-18/ P1-8). <p>STD2 MIKE:</p> <ul style="list-style-type: none"> ● Standard microphone input 2 is selected (P1-9/ P1-8). <p>STD3 MIKE:</p> <ul style="list-style-type: none"> ● Standard microphone input 3 is selected (P1-19/ P1-8). <p>DYN MIKE:</p> <ul style="list-style-type: none"> ● Dynamic microphone input is selected (P1-6/ P1-5). <p>NONE:</p> <ul style="list-style-type: none"> ● No microphone is used in microphone path 2. <p>"MIC ACTIVATION"</p> <p>BOTH MIKES ENABLED:</p> <ul style="list-style-type: none"> ● Input /PTT1 starts transmission from microphone path 1 and 2 (P1-17). ● Input /PTT2 starts transmission from microphone path 2 and path 1 (J1-5). ● Input /IC starts intercom from microphone path 1 and 2 (P1-7). <p>BOTH MIKES DISABLED:</p> <ul style="list-style-type: none"> ● Input /PTT1 starts transmission only from microphone path 1 (P1-17). ● Input /PTT2 starts transmission only from microphone path 2 (J1-5). ● Input /IC starts intercom only from microphone path 1 (P1-7). <p>"OUTPUTS"</p> <p>HDPH 1 ENABLED:</p> <ul style="list-style-type: none"> ● Audio is available on headphone 1 output (P1-2/P1-3). <p>HDPH 1 DISABLED:</p> <ul style="list-style-type: none"> ● No audio is available on headphone 1 output.

Display Contents	Description
	<p>HDPH 2 ENABLED:</p> <ul style="list-style-type: none"> • Audio is available on headphone 2 output (P1-20/P1-22), speaker is not available. <p>HDPH 2 DISABLED:</p> <ul style="list-style-type: none"> • No audio is available on headphone 2 output, speaker is not available. <p>SPEAKER ENABLED:</p> <ul style="list-style-type: none"> • Audio is available on speaker (P1-1/P1-14), headphone 2 is not available. <p>NONE:</p> <ul style="list-style-type: none"> • No audio on headphone 2 output or speaker output.

2.9.12.2 1K065 for General Aviation

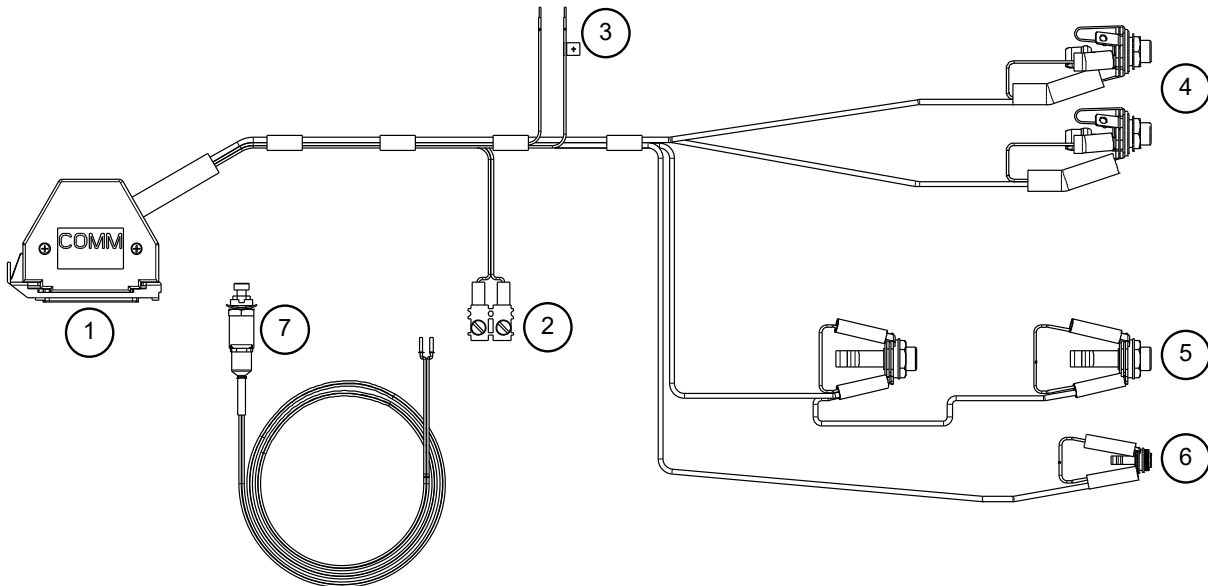

Figure 34: Cable Harness 1K065

- 1 D-Sub connector (to P1 unit connector)
- 2 Connector for PTT switch (see 7)
- 3 Power supply lines
- 4 2x Microphone, jack socket PJ68
- 5 2x Phone, jack socket PJ55
- 6 Audio input, jack socket 3.5 mm
- 7 PTT switch

Order code see: "Accessories", page 41.

2.9.12.3 1K062 (Open Cable Ends)

The same basic construction as type 1K065 only with open cable ends.

2.10 Retrofitting - AR4201 with AR62X1

- The retrofit of the AR4201 with an AR62X1 will not cause any problems.
- Compare if the existing wiring is pin compatible with the AR62X1.
- The connection of the AR62X1 to an AR4201 wiring will NOT damage the AR62X1 or the aircraft installation.

For detailed information please see: [http://www.becker-avionics.com - AR6201 Retrofit-Instructions](http://www.becker-avionics.com - AR6201_Retrofit-Instructions)

2.10.1 Wiring AR4201 - AR62X1

Pin No.	AR4201 Pin Name	AR4201 Function	AR62X1 Pin Name	AR62X1 Function	Full compatible
P1-1	AF-ASYM	Speaker output, unbalanced	SPK_HI	Speaker output, unbalanced	Yes
P1-2	AF-HI	Headphone output, balanced	HDPH1_A	Headphone 1 output, balanced	Yes
P1-3	AF-LO	Headphone output, balanced	HDPH1_B	Headphone 1 output, balanced	Yes
P1-4	AFAUX	Auxiliary audio input, unbalanced	AF_AUX_IN_HI	Auxiliary audio input, unbalanced	Yes
P1-5	MIKE DYN	Dynamic microphone input, high side, unbalanced	MIKE_DYN_HI	Dynamic microphone input, high side, balanced	Yes
P1-6	MIKE GROUND	Ground for dynamic microphone, unbalanced	MIKE_DYN_LO	Dynamic microphone input, low side, <u>balanced</u>	No
P1-7	IC	Intercom input	IC	Intercom input	Yes
P1-8	TEMS1	Input for temperature sensor	MIKE_STD_LO	Ground	No
P1-9	RXD	RS232-serial-data-line	MIKE_STD2_HI	Standard microphone 2 input, high side, unbalanced	No
P1-10	-ILLUMINATION	Illumination, low side	ILL_LO	Illumination, low side	Yes
P1-11	+13.75 V	Positive power supply	P_SUPP	Positive power supply	Yes
P1-12	+13.75 V	Positive power supply	P_SUPP	Positive power supply	Yes
P1-13	GROUND	Power supply ground	P_SUPP_GND	Power supply ground	Yes
P1-14	AF GND MIKE STD GND	Ground	SPK_LO	Ground	Yes
P1-15	AFCU	Normally not used in installation	LINE_OUT	Normally not used in installation	No
P1-16	AGC/AFWB	Normally not used in installation	AGC_OUT	Normally not used in installation	No
P1-17	PTT	Push to talk	/PTT	Push to talk	Yes

Pin No.	AR4201 Pin Name	AR4201 Function	AR62X1 Pin Name	AR62X1 Function	Full compatible
P1-18	MIKE STD1	Standard microphone input, high side, unbalanced	MIKE_STD1_HI	Standard microphone 1 input, high side, unbalanced	Yes
P1-19	CODE PIN	Used for identification of the connection	MIKE_STD3_HI	Standard microphone 3 input, high side, unbalanced	No
P1-20	TEMS2	Headphone 2	HDPH2_A	Headphone 2 output, balanced	No
P1-21	GNDDATA	Ground	AF_AUX_IN_LO	no Ground	No
P1-22	TXD	RS232-serial-data-line	HDPH2_B	Headphone 2 output, balanced	No
P1-23	ILLUMINATION	Illumination, high side	ILL_HI	Illumination, high side	Yes
P1-24	+13.75V TURNED	Power on monitor <u>Turned positive power supply.</u>	/PWR_EVAL	Power on monitor, <u>open collector output, conducting to GND for "On"</u>	No
P1-25	GROUND	Power supply ground	P_SUPP_GND	Power ground	Yes

2.10.2 Dynamic Microphone Input

Retrofitting an AR4201 with the AR62X1 in a typical glider installation with a dynamic microphone:

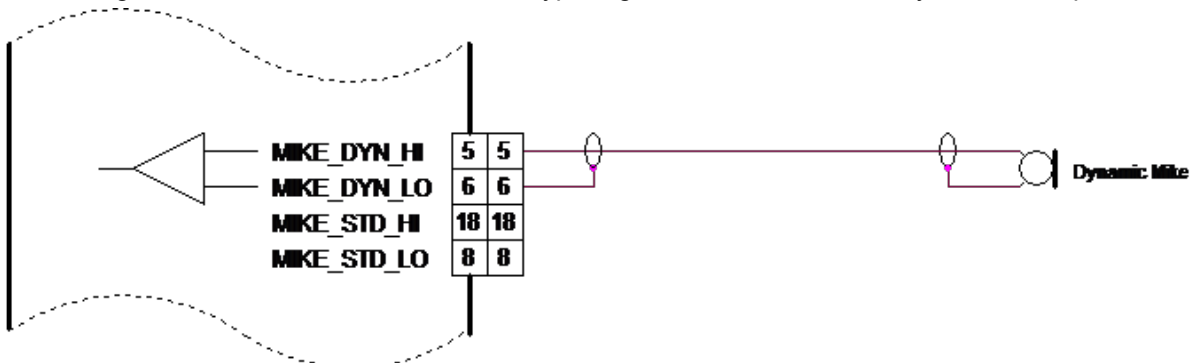

Figure 35: AR62X1 with Wiring Interface for AR4201

- Connect the cable shield to P1-6, which is the low side input for dynamic microphone.
 - Because in AR62X1 this input is balanced, the cable shield is no longer connected to ground (unlike it was with the AR4201). In most cases, it is not a problem.
- If interference with the microphone signal does occur, it is recommended to connect P1-6 with Pin P1-8 (the cable shield is grounded).

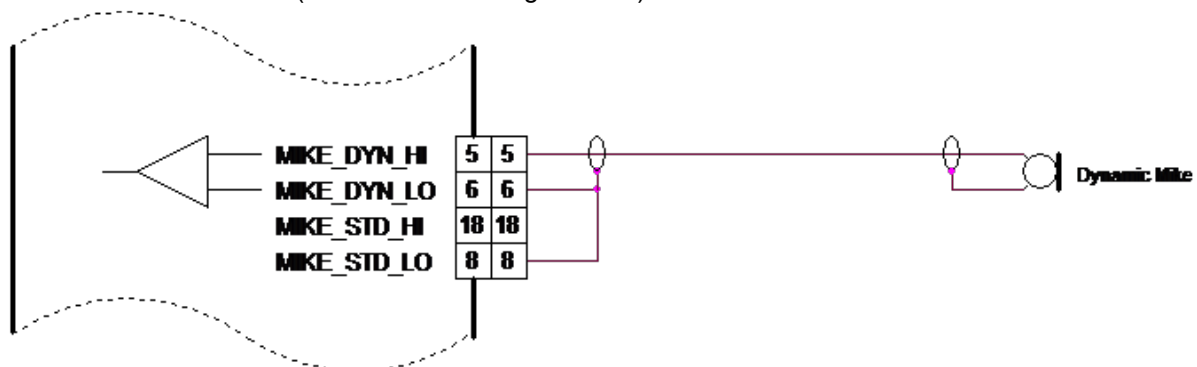

Figure 36: Modified Dynamic Microphone Wiring for AR62X1

2.10.3 Temperature Sensor

- The AR62X1 has no temperature sensor input.
- Remove the wire from P1-8 and P1-20.

2.10.4 RS232 Interface

- The AR62X1 has no RS232 interface for remote control.
- Remove the wire from P1-9 and P1-22.

2.10.5 AFCU/AGC/AFWB

- Not used in aircraft installations.
- Remove the wire from P1-15 and P1-16.

2.10.6 CPIN (if Installed)

- No influence in retrofit installation.
- Remove coding cap from the connector hole.

2.10.7 +13.75 V (AR4201) - PWR_EVAL (AR62X1)

- The AR62X1 has on P1-24 a low signal when the device is turned on and a high impedance signal, when it is turned off.

NOTICE

This is not compatible to the AR4201, which has a positive power supply when it is on and high impedance when it is off.

- When slave equipment is necessary to turn ON/OFF in sync with the AR62X1 connect a relay to P1-24.

2.11 Post Installation Check

Once the device/system is installed completely do a test procedure to make sure the system functionality. Make sure that the compliance with the authority required procedures is obeyed.

The description that follows gives guidance for such tests.

2.11.1 Mechanical Installation and Wiring Check

- Make sure that all cables are fixed securely and shields connected properly to signal ground.
- Examine the movement of controls to make sure that there is no interference.
- Make sure that all screws are tight and the connectors on the rear side of the device are secured.

2.11.2 Power Supply

- Examine the power supply lines and the correct polarity.
- Make sure that the power supply is in the specified limits, with and without a running engine.

2.11.3 Receiver / Transmitter Operation

- Power up the device/system and tune it to a local station for a communication test.
- Make sure that the receiver output supplies a clear and readable audio and ask the local station for proper readability for the transmit signal of the device.
- Repeat this communication test with an airborne station in $\approx 20\text{-}40$ NM (Nautical Miles).

2.11.4 Antenna Check

- Examine the VSWR (voltage standing wave ratio) over the complete frequency band.
- The VSWR ratio should be less than 2:1 and is not acceptable when exceeding 3:1.

2.11.5 Interference Check

- Check the device/system while engine is running and powered on all other avionics/ electrical systems on the aircraft, to make sure that no significant interference exists.
- Check also that the device does not cause significant interference with other systems.
- The installer’s standard test procedure may used for the interference check and the table that follows can be taken as a reference.
- Depending on the individual avionic systems installed in the aircraft, it might be necessary to extend the checklist.

Aircraft System Checklist	Function	
	OK	NOT OK
DME		
Audio		
Generators / Inverters		
GPS System		
Compass 1		
ADF		
VHF / NAV1 all channels		
VHF / NAV 2 all channels		
Marker Receiver		
Motor(s)		
Engine Instruments		
Storm scope		
Transponder		
Air Data Computer		
Autopilot and Servos		

- Power the GPS and make sure that not less than 5 satellites are tracked.
- Check the interference between the VHF-COM and the GPS receiver (when activated in NAV mode).
- Select the channels/frequencies as follows on the device and on each frequency stay in TX and RX mode for at least 30 seconds.
- Make sure that the GPS integrity flag is always out of view.

Channel	Frequency (MHz)	Channel	Frequency (MHz)
121.140	121.1416	131.240	131.2416
121.150	121.1500	131.250	131.2500
121.155	121.1500	131.255	131.2500
121.160	121.1583	131.260	131.2583
121.165	121.1666	131.265	131.2666
121.175	121.1750	131.275	131.2750
121.180	121.1750	131.280	131.2750
121.185	121.1833	131.285	131.2833
121.190	121.1916	131.290	131.2916
121.200	121.2000	131.300	131.3000
121.205	121.2000	131.305	131.3000
121.210	121.2083	131.310	131.3083

For the other avionic equipment repeat all interference tests during a flight and include all equipment not before examined on ground. A communication performance check in the low, mid and high frequency band of the device should be included.

- Make sure that the receiver output supplies a clear and understandable audio output.
- Make sure that the transmitter supplies a report of reliable communications by contacting another station.
- Do a range test with a station at least 100 m from your own position.
- Examine the intercom function by talking into the microphone, while the engine is running at cruising rpm. You should hear yourself and/or your co-pilot loud and clear.
- Turn "ON" the squelch and make sure that the normal radio noise, without a present carrier signal, it will be constantly suppressed. The threshold of the squelch can be set in the user menu.

2.11.6 Flight Test Check

- It is recommended to do a flight test as final installation verification.
- The performance of the device may be examined by contacting a ground station at a range of at least 50 NM while maintaining an appropriate altitude and over all normal flight attitudes.
- Examine the performance in the low, mid and high band frequencies.

2.12 Error / Failure Indication

It is possible to read out and reset error flag.

- For read out and reset see: "Fail List" page 85 and "Erase Memory" page 84 or contact Becker Avionics Customer Service.
- Failure description see: "Warning and Failure Indications" page 140.

2.13 Troubleshooting

If you cannot correct the problem stop using the device(s) and contact authorized maintenance shop for assistance, please.

Problem	Possible Cause / Proposed Solution
No intercom function. (You cannot hear yourself when talking into the microphone).	<ul style="list-style-type: none"> • VOX is turned "OFF" or adjusted to a too high value. <p>Proposed Solution</p> <ul style="list-style-type: none"> • Adjust the VOX to a lower value. A value of "-15" is suitable in most cases. <hr/> <ul style="list-style-type: none"> • The intercom volume is too low. <p>Proposed Solution</p> <ul style="list-style-type: none"> • Adjust the intercom volume to a higher value. A value of "37" supply a quite loud intercom signal. <hr/> <ul style="list-style-type: none"> • The sensitivity of the microphone input is not sufficient. The level is too high. <p>Proposed Solution</p> <ul style="list-style-type: none"> • Adjust the sensitivity of the microphone input to a lower value. For most common avionic headsets is a value of 50...120 mV sufficient.
VOX threshold is not adjustable. VOX is always off.	<ul style="list-style-type: none"> • VOX is inoperative, because the speaker is on. <p>Proposed Solution</p> <ul style="list-style-type: none"> • Turn the speaker off.
Too high cabin noise during intercom / transmit operation.	<ul style="list-style-type: none"> • The sensitivity of the microphone input is too sensitive. <p>Proposed Solution</p> <ul style="list-style-type: none"> • Adjust the microphone sensitivity to a higher value to ensure the cabin noise relatively decreases.
No speaker output.	<ul style="list-style-type: none"> • The speaker is off. <p>Proposed Solution</p> <ul style="list-style-type: none"> • Turn the speaker on.
The noise suppression function of the squelch is not working. (Receiver noise is always present).	<ul style="list-style-type: none"> • Some avionic equipment (especially non ETSO/TSO approved avionic) can cause quite high electromagnetic interference, and the 62XX series device(s) can receive it. <p>Proposed Solution</p> <ul style="list-style-type: none"> • Make the shielding, distance or grounding better to decrease the interference. • Adjust the squelch to a higher value. Notice, a higher value will cause a decreased sensitivity.
Error message on the display (e.g. LOW BATT, STUCK PTT, TX HOT, FAILURE)	<ul style="list-style-type: none"> • An error is occurred. <p>Proposed Solution</p> <p>Refer to "Warning and Failure Indications", page 140.</p>

Problem	Possible Cause / Proposed Solution
Antenna VSWR exceeds 3:1.	<ul style="list-style-type: none"> • Caused by a defective or insufficient counterpoise for the antenna. <p>Proposed Solution</p> <ul style="list-style-type: none"> • Make sure for sufficient size of the counterpoise and make sure there is no mechanical defect on the antenna.
	<ul style="list-style-type: none"> • The impedance of the antenna cable is significantly different from 50 Ω. <p>Proposed Solution</p> <ul style="list-style-type: none"> • Make sure that the antenna cable has 50 Ω impedance. • Make sure that the cable is not bend on its way from the radio to the antenna
	<ul style="list-style-type: none"> • Defective BNC connectors on the antenna cable. <p>Proposed Solution</p> <ul style="list-style-type: none"> • Make sure the proper crimp/solder work on the BNC connectors.

For details about adjustments refer to "Configuration Setup", page 69).

3 Operation

In this chapter you can read about:

3.1	General.....	121
3.1.1	Registration of the Device.....	121
3.2	Device Description	123
3.2.1	Device Assignment	123
3.2.2	Packing, Transport, Storage	123
3.2.3	Scope of Delivery.....	123
3.2.4	State of Delivery.....	123
3.2.5	Type Plate.....	123
3.2.6	Controls and Indications	124
3.2.6.1	User Interface	124
3.2.6.2	Symbols on the Display	125
3.3	Start-Up.....	125
3.4	Receive Mode	126
3.5	Transmit Mode	126
3.6	Frequency Selection Modes	127
3.6.1	Standard Mode	128
3.6.2	Direct Tune Mode	129
3.6.3	Channel Mode.....	130
3.6.3.1	Select Channels	131
3.6.4	Frequency Storage Functions.....	131
3.6.4.1	Store	132
3.6.4.2	Label (Identifier) Data	133
3.6.5	Automatic Storage Function	133
3.6.5.1	Delete data	133
3.6.6	Scan Mode.....	134
3.7	Squelch (SQL).....	134
3.8	RX Field Strength Indication	135
3.9	Channel Spacing.....	135
3.10	Auxiliary Audio Input (AUX INPUT).....	135
3.11	Intercom Operation	136
3.11.1	Pilot Circuit and Passenger Circuit.....	136
3.11.2	Intercom Operation started with VOX.....	136
3.11.3	Intercom Operation started with an Intercom Switch.....	137
3.12	VOX & Speaker Operation	137
3.13	Menus.....	137
3.13.1	User Menu	138
3.13.2	Intercom Menu	139
3.14	Read Out and Reset Error/Failure Flags	140
3.15	Warning and Failure Indications	140
3.16	Contact Data	141

3.1 General

This section contains general information and instructions for safe operation.

3.1.1 Registration of the Device

Obey the national requirements for operation of radio equipment.

NOTICE

- The figures for display content mainly show the transceiver in 8.33/25 kHz mixed mode (pictures for 25 kHz differ only in number of digits for frequency).
- The user can do the HMI operation on the primary controller or on optional secondary controller RCU62X1.
 - The word "frequency" is also used in the sense of "channel name", as defined in EUROCAE, document ED 23B chapter 1.3.2, Volume II.
 - In this document the word "memory channel" or "channel" is also used in the sense of a memory position identified by a channel number, where a frequency may be stored for later use.

NOTICE

- Excessive pulses on the DC bus of the aircraft may cause damage on electrical circuits of any installed instrument.
- Do not turn on the device during engine start or shutdown.

SAFETY INSTRUCTIONS

First make a voice communication test before starting any operation.

- Please notice that, if the communication test is done close to a ground station, the results may be positive even if the antenna cable is broken or short-circuited.

Caution! Then a communication could be not possible at a distance of 5...10 km and above.
- Speak always loud, clear and not too fast for optimal voice communication.
- Keep the microphone always close to the lips otherwise a special suppressing circuit in the VHF COM will not be capable to suppress normal noise.
- Use only microphones or headsets which are suitable for specific installations.
 - In aircraft made of wood, synthetic materials or in gliders or helicopters, incoming radiation can affect the integrated amplifier of the microphone (feedback), then the ground station receives a whistling and/or heavy distortion.

SAFETY INSTRUCTIONS

- If the power supply voltage is less than the adjusted threshold, the display shows the message "LOW BATT".
- If the power supply voltage is < 10.25 V, the device continues operation with decreased performance.
 - The speaker output of the transceiver is automatically turned "OFF".
 - The speaker symbol is no longer shown on LCD.
 - The user must use headphones to continue listening.
- If power supply voltage is < 9.0 Volt, the device turns off automatically.

NOTICE

Some functions and adjustments are only available in the password-protected configuration setup*.

* For details please see chapter "Installation", "Configuration Setup" page 69.

3.2 Device Description

3.2.1 Device Assignment

This manual is valid for the devices:

- See page 45

3.2.2 Packing, Transport, Storage

- See page 44

3.2.3 Scope of Delivery

- See page 45

3.2.4 State of Delivery

- See page 45"

3.2.5 Type Plate

- See page 46

3.2.6 Controls and Indications

3.2.6.1 User Interface



AR6201, AR6211, RCU6201, RCU6211

AR6203, AR6213

Figure 37: Controls and Indicators

	Symbol	Description	Main Function
1		IC/SQL (Intercom/Squelch)	<ul style="list-style-type: none"> "Short push" during normal operation = RX - SQL ON/OFF. "Long push" during normal operation starts the intercom menu.
2		MDE (Mode)	<ul style="list-style-type: none"> "Short push" during normal operation changes to the frequency selection mode. "Long push" during normal operation starts the user menu.
3		STO (Store)	<ul style="list-style-type: none"> "Short push" during normal operation stores the new value.
4		↑/SCN (Exchange/SCAN)	<ul style="list-style-type: none"> "Short push" during standard mode or scan mode changes between preset and active frequency. "Long push" starts the scan mode.
5		Power ON/OFF, volume	<ul style="list-style-type: none"> Turns the transceiver ON/OFF and is used to adjust the volume level of received signals.
6		Rotary encoder	<ul style="list-style-type: none"> Turn the rotary encoder to change the selected parameters (frequency, IC-volume, VOX, ...). Push the rotary encoder to select the digits. Push the rotary encoder to confirm the adjustment.
	-8/25-	Change of channel spacing	<ul style="list-style-type: none"> Push and hold the MOD and STO key at the same time for > 2 s to change 8.33 to 25 kHz channel spacing and vice versa.
7		Display	LCD: Liquid Crystal Display
8		Active frequency	Only on the active frequency: <ul style="list-style-type: none"> Transmission is possible and the reception has priority, even in scan mode. Frequency tuning is not possible in standard mode.
9		Preset frequency	<ul style="list-style-type: none"> Frequency tuning is possible in standard mode. In scan mode both frequencies, active and preset are in listening watch. If no receive signal is detected on the active frequency, receiving signals on the preset frequency will be audible, but will be muted as soon as a signal on the active frequency is detected.



The device identifies a:

"Long push": when you push and hold down a key for > 2 seconds.

"Short push": any push < 2 seconds.

If any action by the user is invalid, the whole display is inverted for a short time.

3.2.6.2 Symbols on the Display

Symbol	Function
IC	The intercom operation is started (triggered by VOX or external IC key).
	The intercom operation with VOX is disabled.
TX	The transceiver is in transmit operation.
SQL	The squelch function is started.
SCAN	The transceiver operates in scan mode.
STO	The transceiver is in a storage procedure.
LOW BATT	The battery voltage is less than the predefined threshold.
	Inverted figures or letters on the display are selected to change.
	The speaker is on.

3.3 Start-Up

- Turn the volume knob clockwise to turn on the device.
- After power-on, the device starts a self-test (PBIT).
 - The display shows the message "WAIT".
 - The display shows the software versions of the control head and the chassis module.
- If there is an error the display shows the message "FAILURE, push any key" (for details see "Warning and Failure Indications", page 140).
- If there is no error the transceiver changes to the last active mode before power off.
- During normal operation, a self-test (CBIT) permanently examines the correct operation of the device.
 - If there is an error the display shows an error message.

3.4 Receive Mode

- If PTT (Push To Talk) inputs are inactive, the transceiver stays in receive mode.
- A mixed signal is supplied on the headphone(s) outputs (if enabled), it is mixed of the:
 - Received signal from antenna.
 - Intercom signal from intercom circuit one and two.
 - Signal from auxiliary input.
- A mixed signal is supplied on the speaker output (if enabled), it is mixed of the:
 - Received signal from antenna.
 - Signal from auxiliary input.
- The signal from the auxiliary input is muted under certain conditions (for details refer to "Auxiliary Audio Input", page 135).
- The signal from intercom is muted under certain conditions (for details refer to "Intercom Operation", page 136).

3.5 Transmit Mode

TX **118.005**

127.000

- If PTT input is started (Push To Talk key is pushed) the transceiver is set to transmit mode.
 - The microphone(s) signals can modulate the transmitter.
 - The PTT 1 input starts transmission from microphone path 1.
 - The PTT 2 input starts transmission from microphone path 2.
 - If "BOTH MIKES" are enabled in the configuration setup*, each input (PTT 1 or 2) can start the transmission from both microphone paths at the same time.
- The "TX" symbol shows that the device is in transmit mode.
- The sidetone (demodulated audio of the emitted signal) is available on the headphone output.
- The transmit mode automatically deactivates the speaker.

* (Details see "Configuration Setup" page 69).

NOTICE

- In transmit mode some user actions are blocked e.g. change the frequency selecting mode or channel spacing mode, which are normally permitted in receive mode.
- Changes in standard mode e.g. the "Preset" frequency are possible even during transmission.
- In transmit mode is no intercom operation possible.
- The transmit mode is automatically terminated (return to receive mode) after 120 s of continuous transmitting.
 - The display shows "STUCK PTT", see "Warning and Failure Indications", page 140.
 - For the start of a new transmission first it is necessary to set the /PTT line inactive.

3.6 Frequency Selection Modes

Available modes:

- Standard mode
- Direct tune mode
- Channel mode
- Scan mode

Standard mode	Direct tune mode	Channel mode	Scan mode
118.005 <small>SQL</small> 127.000	118.005 <small>SQL</small> BAT 13.5V	125.875 <small>SQL</small> <small>CH</small> TWR EDSB 01	118.005 <small>SQL</small> ▶ <small>SCAN</small> 127.000

NOTICE

- The availability of the modes depends on the adjustments in the configuration setup*.

* (Details see "Configuration Setup" page 69).

The modes "Standard Mode", "Direct Tune Mode" and "Channel Mode" have different layouts for the selection of the operating frequency.

- The modes are selectable with short push of the "MDE" key, one after the other.
 - The display shows one by one: "Standard Mode", "Direct Tune Mode" "Channel Mode", "Standard Mode", and so on.
- During the changes between the modes the active frequency is always the same and active.

The mode SCAN is a sub-mode of standard mode and is for monitoring two frequencies at the same time.

- Push "↕/SCN" key (2 s) to start/stop the scan function.

3.6.1 Standard Mode



- Push the "MDE" key to change to the standard mode page.
 - The active frequency is shown in the top line and preset frequency in the bottom line.
- The change of the active frequency is not possible in standard mode (only available in direct tune mode).
 - The change of the preset frequency is possible.

Change the preset frequency in standard mode:

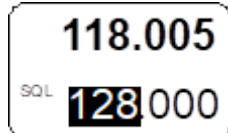

- Make a "short push" on the rotary encoder to change the MHz digits.
 - The changeable digits are shown inverted.
- Turn the rotary encoder clockwise/counter clockwise to change the frequency in 1 MHz steps.

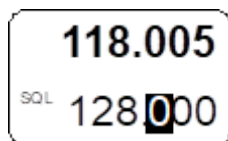

- Make another "short push" on the rotary encoder to change the 100 kHz digit.
 - The changeable digit is shown inverted.
- Turn the rotary encoder clockwise/counter clockwise to change the frequency in 100 kHz steps.

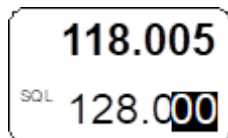

- Make another "short push" on the rotary encoder to change the 25/8.33 kHz digits.
 - The changeable digits are shown inverted.
- Turn the rotary encoder clockwise/counter clockwise to change the frequency in 25/8.33 kHz steps.

NOTICE

- A short push of the "↑/SCN" key, exchanges active frequency to preset frequency and vice versa.
 - While the transceiver operates in transmit mode, the exchange function is disabled.
- Push the "STO" key to store the active frequency into the next vacant memory position of the user channel database (see "Frequency Storage Functions", page 131).

3.6.2 Direct Tune Mode

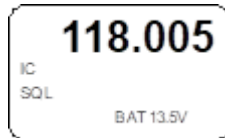

- Push the "MDE" key to change to the direct tune mode page.
 - The active frequency is shown in the top line.
- The battery information is shown.

NOTICE

The battery information is only shown if BATTERY VOLTAGE is selected in the configuration setup*.

* (Details see "Configuration Setup" page 69).

Change the active frequency in direct tune mode:



- Make a "short push" on the rotary encoder to change the MHz digits.
 - The changeable digits are shown inverted.
- Turn the rotary encoder clockwise/counter clockwise to change the frequency in 1 MHz steps.



- Make another "short push" on the rotary encoder to change the 100 kHz digit.
 - The changeable digit is shown inverted.
- Turn the rotary encoder clockwise/counter clockwise to change the frequency in 100 kHz steps.



- Make another "short push" on the rotary encoder to change the 25/8.33 kHz digits.
 - The changeable digits are shown inverted.
- Turn the rotary encoder clockwise/counter clockwise to change the frequency in 25/8.33 kHz steps.

NOTICE

- The changes are active immediately.
 - While the transceiver transmits, the change of the active frequency is not possible.
- Push the "STO" key to store the active frequency into the next vacant memory position of the user channel database (see "Frequency Storage Functions", page 131).

3.6.3 Channel Mode

- The channel mode shows data from the user channels database ("CH"), or last channels database ("LAST").
- The entry shows a customized label (identifier, max. 10 characters), if applied, for the frequency.

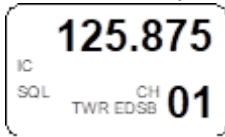

The channel database can store frequencies in channels:

- CH01...CH99 and
- LAST 1...LAST 9.

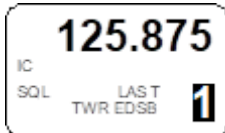

NOTICE

- The functions "LAST" and Store/Restore are only available if they are enabled in the configuration setup* - ("MEM OPTIONS").
- If the device operates in the 25 kHz mode a selection of stored 8.33 kHz channels is not possible.
- For selection of 8.33 kHz channels, the device must operate in 8.33/25 kHz mixed mode.

* (Details see "Configuration Setup" page 69).

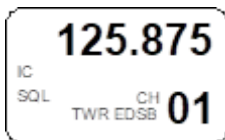

- Push the "MDE" key to change to the channel mode page.
- Use the rotary encoder to select the channel number/frequency.
 - The top line shows the related frequency and the bottom line the customized label (identifier) and the channel number/frequency.
 - If the active frequency is not yet stored, then shows the display "CH--".

3.6.3.1 Select Channels

NOTICE

- The functions "LAST" and Store/Restore are only available if they are enabled in the configuration setup* - ("MEM OPTIONS").

* (Details see "Configuration Setup" page 69).

Example: With CH01 user channel shown on the display:

In order to select the channel number:

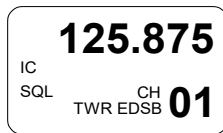

- The first turn clockwise in channel mode starts access to the user channels CH01...CH99.
 - Make a short push on the rotary encoder or:
 - Make one clockwise turn with the rotary encoder.



- The channel number is now highlighted.
- Turn the rotary encoder to select a channel.
- With each step the device tunes immediately to the shown frequency.

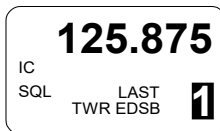

- The first turn counter-clockwise starts access to the channel "LAST 1".
- The channel number is now highlighted.
- One of the nine last used channels is selectable.
- Turn the rotary encoder to select a channel.

NOTICE

- The "LAST" mode is left automatically after a 5 second timeout or stopped by the user with a push on the rotary encoder.
- When leaving the "LAST" channel database and the last shown frequency is not stored in the user channel database, the display shows "CH__".
- Push "STO" to start the storage process.

Cancel channel mode:

- Push the "MDE" key.
 - The channel mode will be closed.
 - The standard mode page is shown.

3.6.4 Frequency Storage Functions

Start store function:

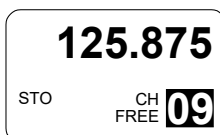

- Push "STO" key. (in "Standard", Direct Tune" or "SCAN Mode").
 - The symbol "STO" is shown.

3.6.4.1 Store

NOTICE

- The functions "LAST" and Store/Restore are only available if they are enabled in the configuration setup* - ("MEM OPTIONS").
* (Details see "Configuration Setup" page 69).

The transceiver has two databases:

- The user channel database - it has 99 channels CH01...CH99 to store frequencies with the possibility to apply a customized label (identifier) with max. 10 alphanumeric characters.
- The last channel database - automatically stores the last used frequencies.
Named and callable as LAST 1...LAST 9, the customized identifier will be shown (if applied).
- You can store frequencies (in the range 118.000...136.9916 MHz) to any channel with a push the "STO" key.
- All 99 channels are changeable.

With the start of the storage procedure, the device proposes the next free channel first.



- The label "FREE" shows together with the channel number if the selected channel is vacant.

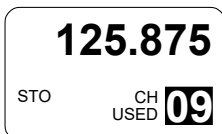

- A selected channel with a stored frequency has the label "USED".

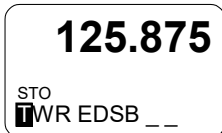

- If the same frequency is stored a second time, then the existing data (frequency, label/identifier data) is offered to store.

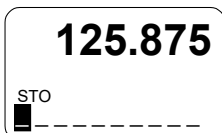

- If the frequency has no label attached, ten underscore digits are shown to give in a label.
- The cursor automatically starts on the first position.

Overview - The user can store data to:

- Next free channel (offered from system).
- A selected free channel.
- A selected used channel (the existing data will be overwritten).

3.6.4.2 Label (Identifier) Data

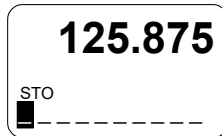

- Turn the rotary encoder to select the characters.
 - The selection works in both directions (example: blank → A → ...Z → 0 → 9 → — → / → blank → A with a turn clockwise or counter clockwise).
 - A short push on the rotary encoder and the cursor is on the next position.
 - A short push on the "STO" key stores the label.
 - A long push on the "STO" key clears the label.
- When the change is stored the transceiver changes to the before selected mode.
- If no action occurs in label editing mode in 7 seconds, the transceiver changes to the before selected mode without storage the frequency and label information.
- Stored frequencies are callable in channel mode (see "Channel Mode" page 130).

3.6.5 Automatic Storage Function

The transceiver stores recently selected frequencies. Named and callable as LAST 1...LAST 9 (see "Channel Mode" page 130).

- When the change to a new active frequency, the before selected active frequency is stored in memory as LAST 1.
- The frequencies stored in LAST 1...LAST 8 are shifted to memory channels LAST 2...LAST 9.

Notice: The functions "LAST" and Store/Restore are only available if they are enabled in the configuration setup* - (page "MEM OPTIONS").

* (Details see "Configuration Setup" page 69).

3.6.5.1 Delete data

The stored data in the user channel database can only be deleted in the configuration setup*. Please notice the whole channel database will be reset.

* (Details see "Configuration Setup" page 69).

3.6.6 Scan Mode



- In scan mode the display shows both frequencies.
 - The active frequency is shown on the top line and the preset frequency on the bottom line.
- The SCAN symbol in the display shows that scan function is started.

In all frequency selection modes:

- A long push (>2 s) of "↕/SCN" key starts the scan function and changes to standard mode, if started from channel or direct tune mode.
- A short push on the "MDE" key or a long push (>2 s) on "↕/SCN" key stops the scan function. The device stays in standard mode.
- The arrow symbol "▶" in front of the frequency shows that this frequency is audible.



If both the active and preset frequency find a signal at the same time, the active frequency (top) has priority.

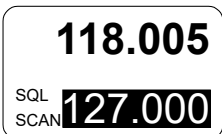

- The preset frequency is shown inverted and blinks.
- An audio notification "beep" tone is audible and the preset frequency blinks to show that there is a RX signal on the preset frequency (if enabled in the configuration setup*).

* Details see "Configuration Setup" page 69.

Reception on preset frequency in scan mode



- If the preset frequency finds a signal and no signal is on the active frequency, the transceiver automatically changes to the preset frequency.
- The arrow symbol "▶" in front of the frequency shows that this frequency is audible.

Notice: For transmission is always the active frequency used, also if the monitored frequency is currently audible.
 If TX on the preset frequency is required, push the "↕/SCN" key to change active and preset frequency.

3.7 Squelch (SQL)

- This function operates independently of the selected operation menu.
- A short push on "SQL/IC" key changes the function to "ON" or "OFF".

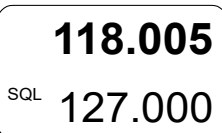

- If the squelch function is active ("ON") the audio noise is muted.

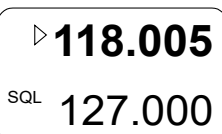

- If the squelch is "OFF" the arrow symbol "▶" in front of the active frequency stay into view all the time.
- Audio noise is audible as long as the signal is received.

- The squelch threshold is adjustable see "User Menu" page 138.

3.8 RX Field Strength Indication

- The field strength is shown with triangle symbol in front of the related frequency (in all frequency selection modes).
- The field strength of a received signal relates to the measured RSSI level ("Received Signal Strength Indication").

Weak Signal Strength	Good Signal Strength	Excellent Signal Strength
RSSI passing squelch levels (empty triangle)	-88 > RSSI > -80 dBm (half-filled triangle)	RSSI > -80 dBm (fully filled triangle)

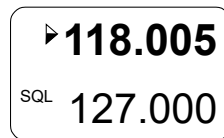

3.9 Channel Spacing

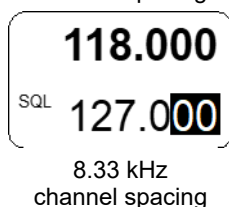
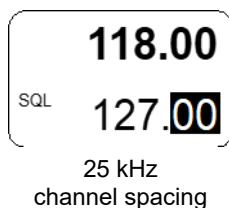

- The transceiver can operate in 8.33 and 25 kHz frequency channel spacing.
- Push and hold the MOD and STO key at the same time for > 2 s to change 8.33 to 25 kHz channel spacing and vice versa.
- In 25 kHz mode, 5 frequency digits are shown.
 - Only operating frequencies with a channel spacing of 25 kHz are selectable.
 - This mode has a faster tuning, because it does not show the 8.33 kHz frequency steps.
- In 8.33 /25 kHz mixed mode 6 frequency digits are shown.
 - The transceiver tunes to all possible frequencies in the aviation VHF frequency band.

Notice:

The 62XX-(0XX) variants can operate in 8.33 /25 kHz channel spacing modes.

The 62XX-(1XX) variants can operate in 25 kHz mode only.

3.10 Auxiliary Audio Input (AUX INPUT)

- The auxiliary audio input is used for e.g. MP3 player connection.
 - This function can be enabled/disabled in the configuration setup* - (page "Configuration").
- With AUX INPUT enabled:
 - The auxiliary audio input signal will be mixed with the received signals from antenna (passing squelch) and the intercom signal (when started).
 - When the intercom operates in isolation mode, the auxiliary audio input signal is audible on headphone 2 output, also if radio communication (transmission/receiving) is started.
- The AUX AUTO MUTE function depends on the AUX INPUT.
 - This function can be enabled/disabled in the configuration setup* - (page "Configuration").
 - This function automatically mutes the audio signal from the auxiliary audio input as long as the device detects (based on squelch evaluation) a RX signal or the user stops the squelch manually.
- With auxiliary input disabled:

- The signal from the auxiliary audio input is permanently audible on the audio output, independently of the received signal or the squelch status.
- Automatic aux attenuation functionality controls the auxiliary audio input.
 - The level of the auxiliary input signal attenuates if intercom is started by VOX or by /IC discrete input.
 - After intercom deactivation, the auxiliary input signal changes to its value before.
 - The attenuation value can be adjusted.

* Details see "Configuration Setup" page 69.

3.11 Intercom Operation

The intercom operation can be started automatically with VOX (with adjustable threshold) or externally with an intercom switch.

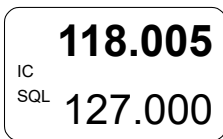

- If intercom operation is started, the "IC" symbol appears in the display.

NOTICE

- The intercom volume and the VOX threshold is adjustable in the intercom menu.

Details see "Intercom Menu" page 139.

3.11.1 Pilot Circuit and Passenger Circuit

- The transceiver has two internal intercom circuits.
- Up to four headsets are connectable.
- The pilot and co-pilot are connected to the first intercom circuit.
 - When intercom is active, both microphone signals are mixed and amplified.
 - The signal is audible on both headphone outputs.
 - The internal communication with headsets between both pilots is possible.
- The passenger headsets are connected to the second intercom circuit.
- ALL mode - Everyone connected to the intercom hear all communications.
 - Pilots hear passengers and passengers hear pilots.
- ISOL mode - Isolated intercoms for the pilots (intercom circuit 1) and the passengers (intercom circuit 2).
 - This lets pilots communicate with each other and air traffic, while the passengers are isolated.
 - The passengers on the intercom circuit 2 can hear auxiliary audio (e.g. from MP3 player) and can communicate with each other.
- An external ISOL input gives the possibility to change between ALL mode and ISOL mode.
- If the PTT1 input is started and ISOL is active the passenger intercom operation on second intercom circuit is still possible.

3.11.2 Intercom Operation started with VOX

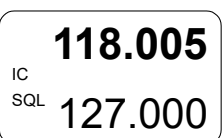

- The intercom operation can be started automatically with VOX.
- The VOX threshold is adjustable in the intercom menu.
 - In tandem installations (application with additional controller) make the adjustments on the primary controller.
 - In tandem installations with a second intercom circuit make the adjustments for the second circuit on the secondary controller.



- The intercom operation cannot be started if:
 - The speaker is enabled (see "VOX & Speaker Operation" page 137).
 - The user turned VOX off.
- The display shows the symbol  if:
 - VOX is off.
 - The speaker is enabled.

3.11.3 Intercom Operation started with an Intercom Switch

- The intercom operation can be started externally with an intercom switch.
 - The external intercom switch has priority.
 - During intercom operation the speaker output is disabled.

3.12 VOX & Speaker Operation

NOTICE



- The speaker always enabled (depends on wiring and configuration).
- To enable/disable the speaker it is necessary to change to the configuration (CFG1, CFG2*) with the related adjustment for the speaker.
 - An external mike switch is necessary to change between the configurations CFG1 and CFG2.
- When the speaker is enabled and not muted, the display will show the loudspeaker symbol.

- When the speaker is enabled and not muted.
 - VOX is forced "OFF".
 - Start of the intercom with VOX is not possible.
- In transmission mode the speaker output is muted ("OFF"), if:
 - The intercom is started with the external intercom switch.
 - The power supply voltage is < 10 V.

* Details see "Configuration Setup" page 69.

3.13 Menus

During normal operation in a frequency selection mode, these menus are available:

- The user menu,
it is for adjustments of panel brightness and squelch threshold.
- The intercom menu,
it is for adjustments of intercom volume and VOX threshold.

3.13.1 User Menu

- A long push (>2 s) on "MDE" key starts the user menu.
- The menu has two pages:
 - BRIGHTNESS
 - SQUELCH TRH
- A short push on "MDE" key or the rotary encoder changes the pages.



BRIGHTNESS:

- The display shows the active frequency in the top line.
- The adjustable value is shown as bar graph and as numerical indicator in the bottom line.
- The brightness is adjustable from 0...100 (rotary encoder).
 - 0, illumination is off.
 - 100, maximum brightness.

Notice:

This page is not available if the dimming input is set to 14 V or 28 V in the configuration setup*.

For this adjustment, the dimming circuit controls the brightness parameters.

*Details see "Configuration Setup" page 69.

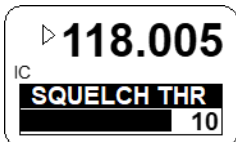

SQUELCH TRH:

- The display shows the active frequency in the top line.
- The adjustable value is shown as bar graph and as numerical indicator in the bottom line.
- The squelch threshold is adjustable from 6...26 (rotary encoder).
 - 6, very weak signals are audible with high noise content; squelch opens at about -105 dBm.
 - 26, only quite strong signals are audible with low noise content; squelch opens at about -87 dBm. The receiver sensitivity is very decreased.

Cancel the menu:

- Automatically after 5 seconds timeout.
- Another long push (>2 s) on "MDE" key.
- A short push on the rotary encoder when the "SQUELCH TRH" page is started.

3.13.2 Intercom Menu

- A long push (>2 s) on "IC/SQL" key starts the intercom menu.
- The menu has two pages:
 - IC VOLUME.
 - IC VOX.
- A short push on " IC/SQL" key changes the pages.



IC VOLUME:

- The display shows the active frequency in the top line.
- The adjustable value is shown as bar graph and as numerical indicator in the bottom line.
- The intercom volume is adjustable from 0...46 (rotary encoder).
 - The intercom volume affects the intercom audio and sidetone.
 - The changes are active immediately.

Notice:

Access to the VOX threshold level is not possible if VOX is forced "OFF".

Access to the VOX threshold level is not possible if the speaker is enabled.

Details see "VOX & Speaker Operation" page 137 and "Configuration Setup" page 69.



IC VOX (threshold):

- The display shows the active frequency in the top line.
- The adjustable value is shown as bar graph and as numerical indicator in the bottom line.
 - The VOX threshold is adjustable from -30...+10 (rotary encoder).
 - -30, most sensitive, a very low microphone signal starts the intercom operation.
 - +10, less sensitive, only a high microphone signal starts the intercom operation.
 - The changes are active immediately.

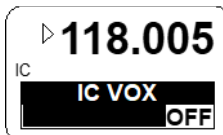

- With an adjustment of >+10 is the VOX operation disabled.
 - The word "OFF" replaces the numerical value indication.
 - The activation of intercom operation with an external intercom switch is still possible at any time.

NOTICE

- In tandem installation:
 - The primary controller adjusts VOX threshold for first intercom circuit.
 - The second controller (RCU62X1) adjusts VOX threshold for second intercom circuit.

Cancel the menu:

- Automatically after 5 seconds timeout.
- Another long push (>2 s) on "MDE" key.

NOTICE

- The adjustment of -15 for VOX threshold is a convenient behavior in most aircraft.
 - This made a correct adjustment for the mike sensitivity necessary (see configuration*).

* Details see "Configuration Setup" page 69.

3.14 Read Out and Reset Error/Failure Flags

NOTICE

The fail list (fail history) is only available in the password-protected configuration setup*.

* For details please see chapter "Installation", "Configuration Setup" page 69.

3.15 Warning and Failure Indications

Display Contents	Description
<p>IC</p> <p>118.005</p> <p>LOW BATTERY</p> <p>at intervals of 3 s</p>	<p>"LOW BATTERY":</p> <ul style="list-style-type: none"> The supply voltage of the transceiver is less than the threshold adjusted in the configuration setup. The device is operable but it can have a decreased performance depending on supply voltage. <p>Possible cause:</p> <ul style="list-style-type: none"> Accumulator capacity problems Power interrupts. General power supply problems. <ul style="list-style-type: none"> Adjustment for low battery threshold too high.
<p>IC</p> <p>118.005</p> <p>STUCK PTT</p> <p>at intervals of 3 s</p>	<p>"STUCK PTT":</p> <ul style="list-style-type: none"> The transmit mode is automatically terminated (return to receive mode) after 120 s of continuous transmitting. The transceiver goes back to receive mode also if the PTT line is still active (GND). <p>Possible cause:</p> <ul style="list-style-type: none"> Transmission continues more than 120 seconds. Frequent overriding can decrease the MTBF. PTT-key is stuck. PTT line permanently grounded (short circuit in installation). <p>Notice: For the start of a new transmission it is necessary to set the /PTT line inactive (open).</p>
<p>IC</p> <p>118.005</p> <p>TX HOT</p> <p>at intervals of 3 s</p>	<p>"TX HOT":</p> <ul style="list-style-type: none"> "TX HOT" is shown if the internal device temperature is > +90 °C. Transceiver is still operable. The performance of transmitter is decreased. <p>Possible cause:</p> <ul style="list-style-type: none"> Very high environmental temperature, long transmissions times and airflow conditions are not sufficient.
<p>IC</p> <p>118.005</p> <p>FAILURE</p> <p>at intervals of 3 s</p>	<ul style="list-style-type: none"> The transceiver has found an internal failure during normal operation. Depending on failure cause, the device is operable with decreased performance, or not operable at all. <p>Possible cause:</p> <ul style="list-style-type: none"> Specified environmental conditions. <ul style="list-style-type: none"> HW or SW failure inside the transceiver.

Display Contents	Description
<div style="border: 1px solid black; border-radius: 10px; padding: 10px; text-align: center;"> <p>FAILURE PRESS ANY KEY</p> </div>	<ul style="list-style-type: none"> • The transceiver has detected an internal failure during start up. • Depending on failure cause, the device is operable with decreased performance or not operable at all. <p>Possible cause:</p> <ul style="list-style-type: none"> • Outside specified environmental conditions. <ul style="list-style-type: none"> • HW or SW failure inside the transceiver.
<div style="border: 1px solid black; border-radius: 10px; padding: 10px; text-align: center;"> <p>FAILURE</p> </div>	<ul style="list-style-type: none"> • The transceiver has no communication with the controller. • Depending on failure cause, the device is operable with decreased performance or not operable at all. <p>Possible cause:</p> <ul style="list-style-type: none"> • Problem with the interwiring.

Contact maintenance shop for assistance, if you cannot find the failure.

3.16 Contact Data

In case of additional questions contact your local Becker Avionics dealer or forward your request direct to Becker Avionics "Customer Service".

In the event of damage or a defect, the entire device must be returned for repair. The repair must be done by trained Becker Avionics personnel.

For relevant department and addresses, please see contact info page 2.

Any change by the user excludes any liability on our part (excluding the work described in this manual).

4 Index

Abbreviations	8	ISOL Mode	136
Accessories	41	LOW BATT Indication	23
AF Auxiliary Input.....	22	Memory Channels	23
Airworthiness	30	Menus	137
ALL Mode	136	Mike Inputs.....	22
Antenna Installation	66	Non-Warranty Clause	11
AR62X1 Single Block Transceiver.....	20	Preset Frequency in Scan Mode.....	134
AR62X3 Single Block Transceiver.....	20	RCU62X1 Remote Control Unit.....	21
Audio Outputs	22	Receive Mode	126
Automatic Storage Function	133	RT62X1 Remote-Controlled Transceiver.....	21
Auxiliary Audio Input.....	135	RX Field Strength.....	135
Brightness.....	138, 139	Safety Definitions	10
Built-in Tests PBIT, CBIT.....	23	Scan Mode	23, 134
CBIT.....	23	Service Mode	24
Channel Mode	130	Sidetone	23
Conditions of Utilization	11	Squelch	134, 138
Configuration	24	Squelch Operation	23
Configuration Setup.....	69	Standard Mode.....	128
Connector Layout	57	Stuck PTT	126
Dimensions	50	Tandem Operation	24
Direct Tune Mode	129	Transmit Mode	126
Emergency Operation.....	23	Type Plate	46
Factory Default Settings	86	Units	9
Frequency Selection Modes	127	User Interface.....	124
Illumination.....	23	User Menu.....	138, 139
Installation Requirements	47	Variants Overview	16
Intercom Operation	24	Warning and Failure Indications	140
Intercom Operation with Intercom Switch...	137	Warranty Conditions	11
Intercom Operation with VOX.....	136	Wiring.....	88

We reserve the right to make technical changes.
 The data correspond to the current status at the time of printing.
 © by Becker Avionics GmbH / all rights reserved

***** End of the Document *****